

The Mobile Instrument Table slides easily over all standard small animal surgery tables. A handle adjusts the tabletop height. This specification includes dimensions and materials pertaining to this model.

Dimensions	
Physical Dimensions	
Overall Height (A)	See "Dimensions"
Overall Width (B)	63.50 cm (25 in)
Overall Length (C)	101.60 cm (40 in)
Work Surface	101.60 cm x 58.42 cm (40 in x 23 in)
Floor Surface Area	0.65 sq m (6.94 sq ft)
Table Capacity	45.36 kg (100 lbs)
Weight	
Weight	39.01 kg (86 lbs)
Materials	
Tabletop	Series 304 Stainless Steel*
Frame	Series 304 Stainless Steel*
Casters	Reinforced Nylon
* Series 304 is referred to as medical grade due to its composition.	

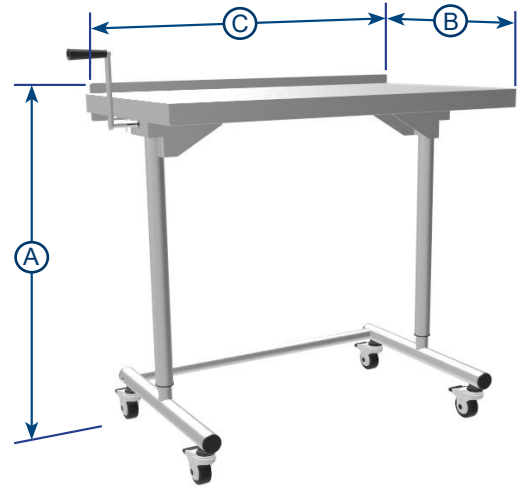

Dimensions*				
Table Position	A - Height	B - Width	C - Length	Weight
Down	101.60 cm (40 in)	63.50 cm (25 in)	101.60 cm (40 in)	39.01 kg (86 lbs)
Up	134.62 cm (53 in)			
* Lift crank handle not included in dimensions.				

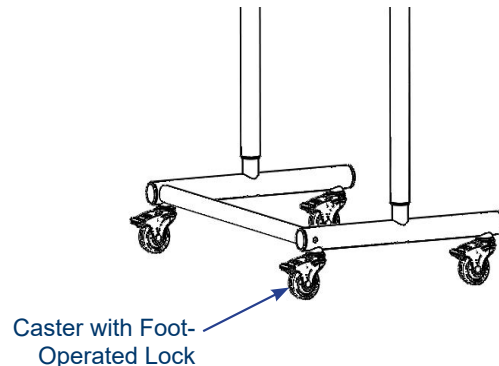
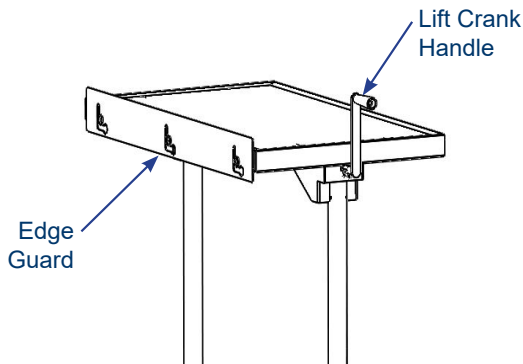

NOTE:

- Table is equipped with an edge guard located on back side of tabletop to prevent items from falling off.
- A lift crank handle adjusts tabletop height.
- Table measures 33" between table legs.