



VIP 3000 Calibrated Vaporizer

For Models:

91305430

91305507

91305418

91305534

91305535

91305537

40140201

R/R-ISO VAP

R/R-SEVO

Vap



Setup + User Guide

Product Information

Dealer :

Date of Purchase:

Model / Serial Number:

**Model / Serial
Number Location**

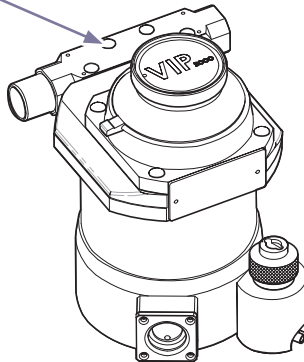

Calling for Service

Note

Model / serial number information is required when calling for service.

If service is required, contact Midmark directly:

US 844.856.1232 / Canada 937.526.8585
Monday-Thursday 8:00 AM until 6:00 PM
Friday 8:00 AM until 5:00 PM (ET)
midmark.com

Important Information

Calling for Service 2
Safety Symbols - Transportation / Storage Conditions 4
Intended Use - Requirements..... 5
Warnings and Cautions 6
Description..... 8
Specifications 9

Operation

Performance Curves..... 10
Effects of Variables..... 12
Principal of Operation 14
Installation 16
Operating Instructions 17
Calibration 23

Maintenance

Periodic Maintenance 25

Warranty

Scope of Warranty..... 27

Important Information - Safety Symbols



WARNING

Indicates a potentially hazardous situation which could result in serious injury.



Caution

Indicates a potentially hazardous situation which may result in minor or moderate injury. It may also be used to alert against unsafe practices



Equipment Alert

Indicates a situation which could result in equipment damage.

Note

Amplifies a procedure, practice or condition.

Symbol Glossary

These symbols may appear on your equipment and/or in the manuals.



Proper Shipping Orientation



Consult User Guide



Maximum stacking height
(Do not stack)



Do Not Tumble



Fragile



Handle With Care



Keep Dry

Transportation / Storage Conditions

Ambient Temperature Range:..... 50°F to 104°F (+10°C to +40°C)
Relative Humidity..... 10% to 90% (non-condensing)
Atmospheric Pressure700hPa (20 in. Hg) to 1060hPa (31 in.Hg)

Intended Use

Federal law restricts this device to sale by or use by a veterinarian.

Authorized EU Representative

Countries in the EU should direct all questions, incidents, and complaints to Midmark's Authorized EU representative listed below.

Newmed Srl.
Via Lenin 79/A
Quattro Castella (RE), 42020, Italy
Phone: +39.0522.875.166
Fax: +39.0522.243.096

Disposal of Equipment

At the end of product life, this product may become contaminated from normal use. Consult local codes and ordinances for proper disposal of equipment, accessories and other consumable goods.

Warning and Cautions



1. Federal law restricts this device to sale by or use by a veterinarian.
2. The VIP 3000 calibrated vaporizer is designed for use with one anesthetic agent only, which is that named on the vaporizer. Incorrect dosage may result if the wrong agent is used in this vaporizer. National and international standards are provided for by the key filled version of this vaporizer.
3. The VIP 3000 vaporizer must be secured in the upright position before it is connected to a patient. Excess dosage may be delivered if the vaporizer is moved suddenly during use.
4. When the VIP 3000 calibrated vaporizer is filled with anesthetic agent, the dial control must be set at "OFF", also when not in use and/or during transportation. The vaporizer must be secured in the upright position for a minimum of 10 minutes before it is connected to a patient via a breathing system. Excess dosage may be delivered if adequate time is not allowed for the liquid agent to return to its normal level. If the vaporizer has been transported with the dial control set at any position other than "OFF", or was transported other than in an upright position, it must be flushed with oxygen at 4 liters/minute for a minimum of 2 minutes to prevent incorrect dosage. If the vaporizer has been dropped, it **MUST** be returned to a Midmark authorized Service Center for functional checks.
5. Anesthetic agents are drugs; to prevent the hazard of prolonged inhalation of trace concentrations from the atmosphere, great care must be taken to avoid spilling of any agent during filling or draining. Patient exhaled anesthetic gases should be extracted from the operating theater by an approved anesthetic gas scavenging system.
6. The dial control **MUST** be set at "OFF" during all filling and draining operations. To prevent over filling, the vaporizer **MUST** be secured in the upright position during the filling process. The filler Screw Cap must be tightened during use; the delivered concentration will be incorrect if the filler port is open during use.
7. During use, frequently check that the liquid lever is between the minimum and maximum marks on the sight glass level indicator. Refill the vaporizer before the liquid level reaches the minimum mark (▼) in the level indicator.
8. The VIP 3000 calibrated vaporizer may cease to function correctly if it is exposed to excessive temperature. Always store and empty the vaporizer at temperatures between -5°F and 122°F (-20°and 50°C).
9. The output of the VIP 3000 calibrated vaporizer is sensitive to barometric pressure. It may be necessary to use a correction factor when analyzing the output, especially at high altitudes. The barometric pressure is not normally of clinical importance.
10. Anesthetic agents must be treated as pharmaceutical products; to avoid contamination, liquid agent must **NEVER** be drained into an open container and/or re-used. The liquid must **ALWAYS** be disposed of as a hazardous chemical.

Warning and Cautions continued...

11. The VIP 3000 calibrated vaporizer must NEVER be modified, dismantled, calibrated or serviced by unauthorized personnel. The calibrated vaporizer MUST be serviced at a Midmark authorized Service Center.
12. The VIP 3000 calibrated vaporizer MUST be connected so that the flow of the gas to the patient is as indicated by the arrows on the device. The delivered concentration will be incorrect if the flow is reversed.
13. The VIP 3000 calibrated vaporizer has a relatively high resistance and must not be incorporated in a breathing system downstream of the common gas outlet.
14. Before use, ALL connections must be checked for leaks and functional tests MUST be performed as described in the anesthetic machine User Manual.



WARNING

This product can expose you to chemicals including Nickel (Metallic), which is known to the state of California to cause cancer.

For more information go to www.p65warnings.ca.gov

User Responsibility

The VIP 3000 calibrated vaporizer must be checked periodically. It must be operated and maintained in accordance with the instructions provided. A known defective or damaged vaporizer must not be used. Components, which are damaged, worn, distorted, broken, contaminated or missing must be replaced immediately. Should such repair or replacement be necessary, Midmark recommends that a verbal or written request be made only to a Midmark authorized agency. The vaporizer must not be altered or modified in any way without prior written consent from Midmark. The user of this vaporizer shall have sole responsibility for any malfunction, which results either from alteration by anyone other than Midmark authorized personnel, or from improper use, incorrect maintenance, improper repair or damage.

Servicing

Only qualified service personnel must service the VIP 3000 calibrated vaporizer. The contents of this manual are not binding. If any significant differences are found between the product and this manual, please contact Midmark for further information.

To ensure that the VIP 3000 calibrated vaporizer functions correctly, it must be serviced at regular intervals at a Midmark authorized Service Center. Midmark recommends that the vaporizer should be serviced at intervals not exceeding 12 months.

Qualified service personnel and genuine spare parts must be used for all servicing and repair requirements. Midmark will otherwise not assume responsibility for the materials used, the work performed, or any possible consequences of the same.

Description

General

When communicating with Midmark, please quote the model and serial number of the vaporizer, along with the approximate year of purchase. If the unit is being returned for repair, indicate the nature of the fault or the work required to be undertaken. Midmark can be contacted by telephone by dialing 1-800-Midmark, (US & Canada).



WARNING

This manual and all its associated documentation must be studied thoroughly before any attempt is made to install, operate or maintain any part of the VIP 3000 calibrated vaporizer. Failure to do so may result in patient injury.

The VIP 3000 calibrated vaporizer is designed for “out of circuit” use in continuous flow techniques of inhalation anesthesia.

The VIP 3000 calibrated vaporizer is temperature and flow compensated so that its output remains relatively constant despite cooling due to the vaporization and variations in inlet flow.

Every VIP 3000 calibrated vaporizer is labeled to show the name of the anesthetic agent for which it is designed and calibrated.

Inlet (Cagemount)

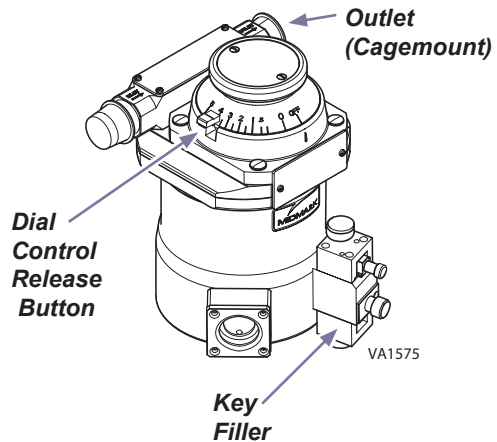
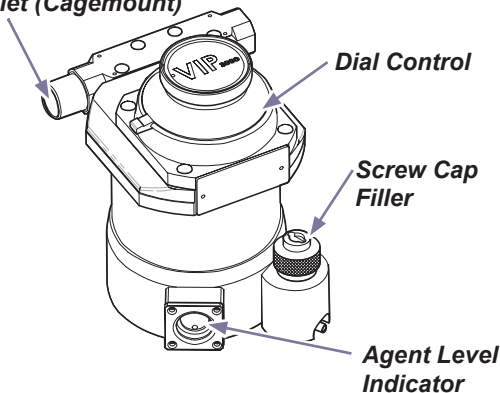

To set the desired concentration of anesthetic agent, a single Dial Control with a concentration scale calibrated in % of anesthetic agent vapor per volume (v/v) is used. This Dial Control incorporates a release button to help prevent accidental rotation of the dial from the “OFF” to the “ON” position. A counter-clockwise rotation of the dial and simultaneous depression of the release button is required to set the vaporizer to the on position.



WARNING

Turn the vaporizer dial control to “OFF” when not in use.

Specifications

Resistance to Gas Flow

5 centimeters of Water (cm. H₂O) at the "OFF" setting at 5 liters/minute (LPM) O₂.

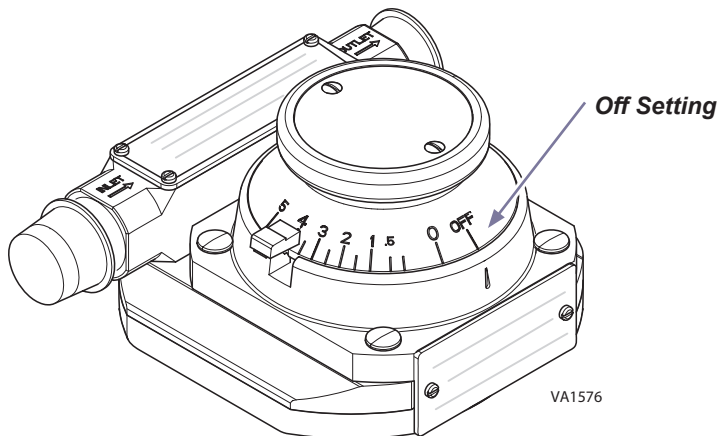

Liquid Capacity

Amount of anesthetic agent to fully charge the vaporizer = 125 milliliters (ml.) (nominal). Amount retained by wick system = 35 ml (nominal).

Weights and Dimensions

Weight 15 lbs. (6.8 kg.)

Height 8 in. (205 mm.)

Width 5.3 in. (135 mm.)

Depth 5.5 in. (140 mm.)

Temperature Range

The VIP 3000 calibrated vaporizer is designed to operate at temperatures between 59°F (15°C) and 96.8°F (36°C).

Calibration

VIP 3000 calibrated vaporizers are calibrated at 70°F +/- 3°F (21°C +/- 2°C). The variation in output with temperature, flow rate and duration of use is small, and the variation of output when used with intermittent positive pressure ventilation is negligible. The Dial Control is calibrated to the levels shown on the following performance curves.

Performance Curves

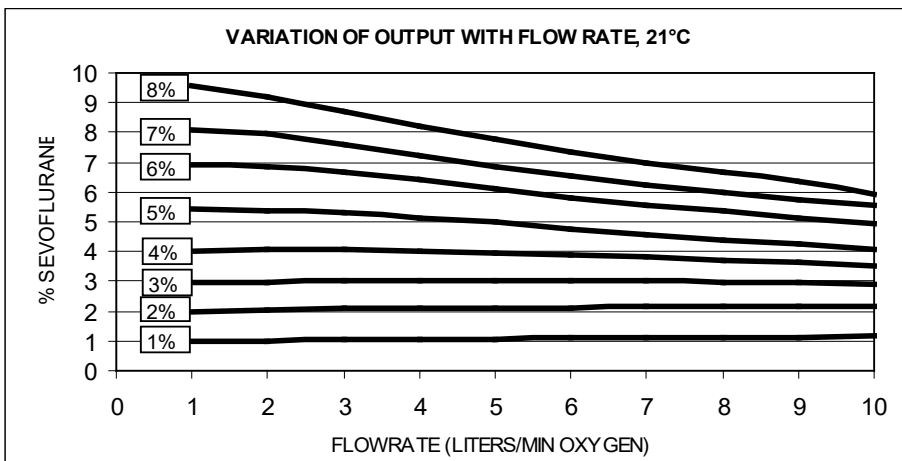
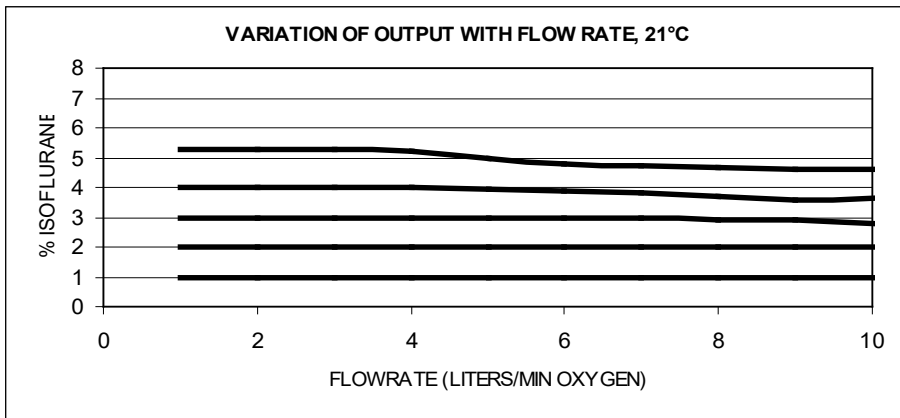

Performance Curves continued...

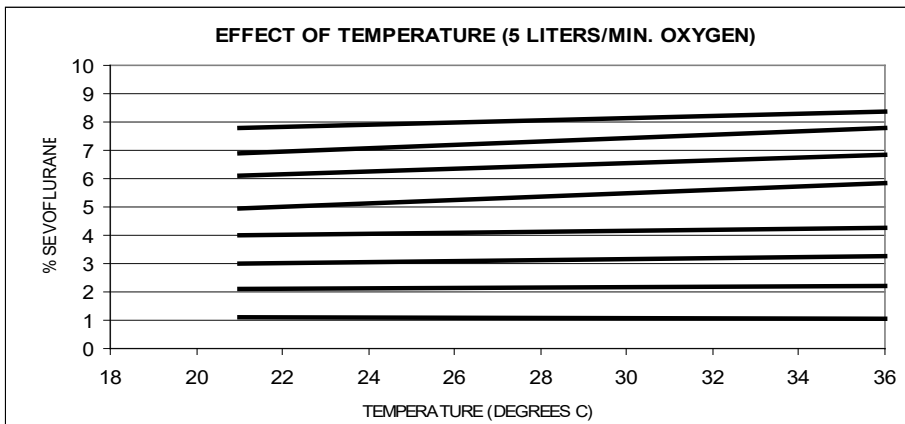
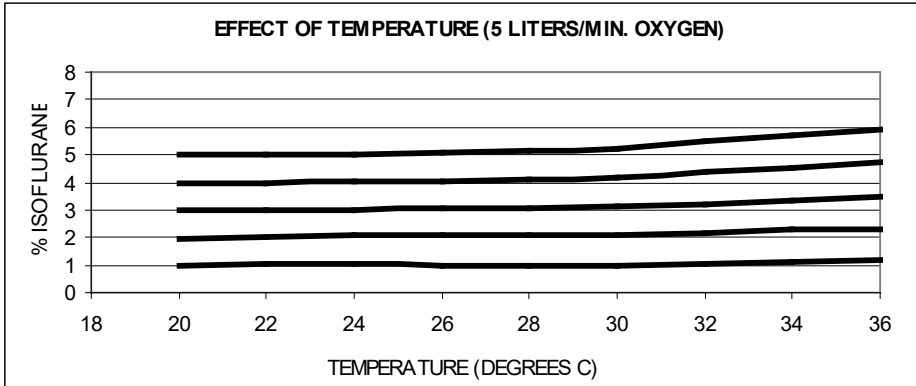

Effects of Variables

Anesthetic Consumption

The rate of consumption of anesthetic agent depends primarily on flow rate and vapor output concentration. As an approximate working figure, 1.0 milliliter of liquid agent is required to provide 200 milliliters of vapor at room temperature. The approximate hourly consumption in milliliters of agent can be expressed as follows:

$3 \times \% \times F$, where % = the setting of the output percentage, F = input flow rate in liters/ minute.

Example: if a vaporizer is set to deliver 2% @ 2 liters/minute total input gas flow rate: approximate rate of agent consumption = $3 \times 2 \times 2 = 12$ milliliters/hour.

The figures are intended only for clinical guidance and are approximate. They may vary depending on the type of anesthetic agent used, accuracy of graduation of flow meters, etc., and will vary greatly if the vaporizer filler/drain port is not fully closed.

Temperature

The effects of variation in temperature are normally negligible at commonly used combinations of dial setting and ambient temperature.

The VIP 3000 calibrated vaporizer responds very slowly to changes in ambient temperature and, as a safety feature, the temperature sensitive valve does not respond to temperatures below the range of approximately 53.5°F (12°C) to 59°F (15°C), thus preventing the valve from closing completely.

Should the VIP 3000 calibrated vaporizer temperature fall lower than this, the output can be expected to be lower than that indicated on the dial control.

At temperatures above the range shown on the performance curves, the VIP 3000 calibrated vaporizer output may be unpredictably high, particularly if the temperature approaches the boiling point of the anesthetic agent.

To avoid inaccuracies due to extreme temperatures, the VIP 3000 calibrated vaporizer should be allowed to attain a temperature in the range shown on the performance curves prior to use.

Carrier Gas Composition

Small effects can occur when the carrier gas composition is changed from oxygen to either an oxygen/air or a nitrous oxide/oxygen mixture. As a general rule, variation of output with carrier gas composition can be considered of negligible clinical significance, since any effects are normally less than 10% of setting. Where changes do occur, the usual effect is that the output is slightly depressed when nitrous oxide is employed, compared to the output when only oxygen is the carrier gas. The presence of nitrous oxide reduces the required inspired concentration of volatile agent and this mitigates this small depression in output.

Effects of Variables *continued...*

Barometric Pressure

The dial control is graduated in v/v percentage at 760 millimeters of mercury (mm-Hg). If the ambient pressure changes, the v/v% changes so that at an ambient pressure (P) mm-Hg, the delivered percentage (D) = Equation 1: $D = (\% \times 760) / P$; where % is the nominal setting of the vaporizer.

It is generally accepted that the depth of anesthesia depends on the inspired partial pressure of agent and not the concentration by volume of agent.

To obtain a consistent depth of anesthesia when gross changes of barometric pressure occur, the v/v% must be changed in inverse proportion to the barometric pressure. The VIP 3000 calibrated vaporizer automatically makes this change, thus the effects of change in barometric pressure can be ignored for practical clinical purposes.

Back Pressure (Steady)

Low and Moderate Pressure

The VIP 3000 calibrated vaporizer cannot distinguish between pressures at the outlet due to barometric pressure and pressures in excess of barometric pressure which are due to steady back pressure applied by downstream components. Equation 1 above therefore applies with P now being the absolute pressure at the outlet, i.e. barometric pressure plus backpressure. Steady backpressure reduces the v/v percentage.

Currently, it is unlikely that the steady backpressure imposed by commonly used downstream components (other than some ventilators) will exceed 30 mm-Hg at commonly used flow rates. Back pressures as high as this would reduce the delivered v/v percentage at 760 mm-Hg barometric pressure to:

Equation 2: $760/790 = 0.96$ of what would otherwise be expected. Under normal clinical circumstances, effects of this degree can be ignored.

High Pressure

Pressures, in excess of approximately 400 mm-Hg, should not be imposed on the VIP 3000 calibrated vaporizer, since this may overcome the loads imposed by internal thrust springs.

Back Pressure (Fluctuating)

Fluctuating backpressure may be imposed on the VIP 3000 calibrated vaporizer by downstream components and assisted or controlled ventilation to the patient. This can affect the vaporizer and increase the concentration by intermittently altering the pressures, and hence the flow distribution within the vaporizer. The greatest effects are observed at combinations of very low flow rates and low dial settings with large and rapid pressure fluctuations. This becomes progressively unimportant as the dial setting and flow rate increase and the magnitude and rate of cycling of the pressure fluctuations decrease.

In clinical use, VIP 3000 calibrated vaporizers are considered unaffected by all fluctuating backpressures which would occur under all normal clinically encountered conditions relating to anesthesia.

Effects of Variables continued...

Time Out of Service

If the anesthetic machine on which the VIP 3000 calibrated vaporizer is left for a period of time with no gases flowing, sensitive analyzers may detect small concentrations of agent at the anesthetic machine's outlet when the gas flow is turned "ON" and the vaporizer is set to "OFF". This concentration can be expected to decrease rapidly to zero within approximately 15 seconds at flow of 5 LPM, for example. This phenomenon is a normal characteristic of anesthetic vaporizers and anesthetic machines. It is considered to be clinically insignificant because of the small volume of vapor involved

Other Variables

Ambient temperature, input flow rate and duration can often affect delivered concentrations, particularly when the vaporizer is used at extremes of the usual clinical range. The valve design and temperature compensation system of the VIP 3000 calibrated vaporizer reduces the effects to levels where, under most clinical conditions, their effect on vaporizer performance is not clinically significant. The nominal performance characteristics should be consulted for further details.

Principal of Operation

Vaporizer Sump and Valve Assembly

The vaporizing chamber is lined with two concentric wicks, which enclose a metal helix, so that the space is converted into a long spiral outlet channel. The wicks are in contact with the liquid agent, thereby ensuring that the vapor is maintained at saturation concentration in the gas leaving the vaporizing chamber.

The amount of anesthetic agent picked up in the vaporizing stream can vary, due either to variation in room temperature or the cooling which takes place as the agent is vaporized. Each variation causes changes in the effective vapor pressures of the anesthetic agent, therefore, unless some form of compensation device is used, the output of the vaporizer for any given flow and dial setting would change with changes in temperature. The VIP 3000 calibrated vaporizer incorporates a temperature-compensating device (thermostat) that utilizes a bi-metallic strip that deflects according to temperature in order to control the proportion of carrier gas entering the vaporizing chamber.

If the temperature of the VIP 3000 calibrated vaporizer decreases, the thermostat closes and more carrier gas is admitted into the vaporizing chamber. If the temperature of the vaporizer increases, the thermostat opens and less carrier gas is admitted into the vaporizing chamber. In this way, the output of the vaporizer remains constant under conditions of changing temperature within the range specified.

Principle of Operation *continued...*

Operation Schematic

When the dial control is set at “OFF”, fresh gas enters the central chamber (A) and leaves via outlets (B) and (C). When the dial control is rotated to the on position, the bypass outlet (B) is occluded. Fresh gas enters and is split to the rotary valve inlet (A) and the inlet bypass chamber (C). Bypass gas passes through (C) to the temperature compensated bypass chamber. The other gas stream passes through the vapor chamber inlet (D) and is ducted down the the inside of the inner wick support to the base of the vaporizing chamber.

- A) Rotary Valve Inlet
- B) Rotary Valve Outlet
- C) Inlet to Bypass Chamber (Thermostat)
- D) Vapor Chamber Inlet
- E) Outlet: Vapor Chamber to Calibrated Channel
- F) Outlet: Calibrated Channel to Vapor Outlet

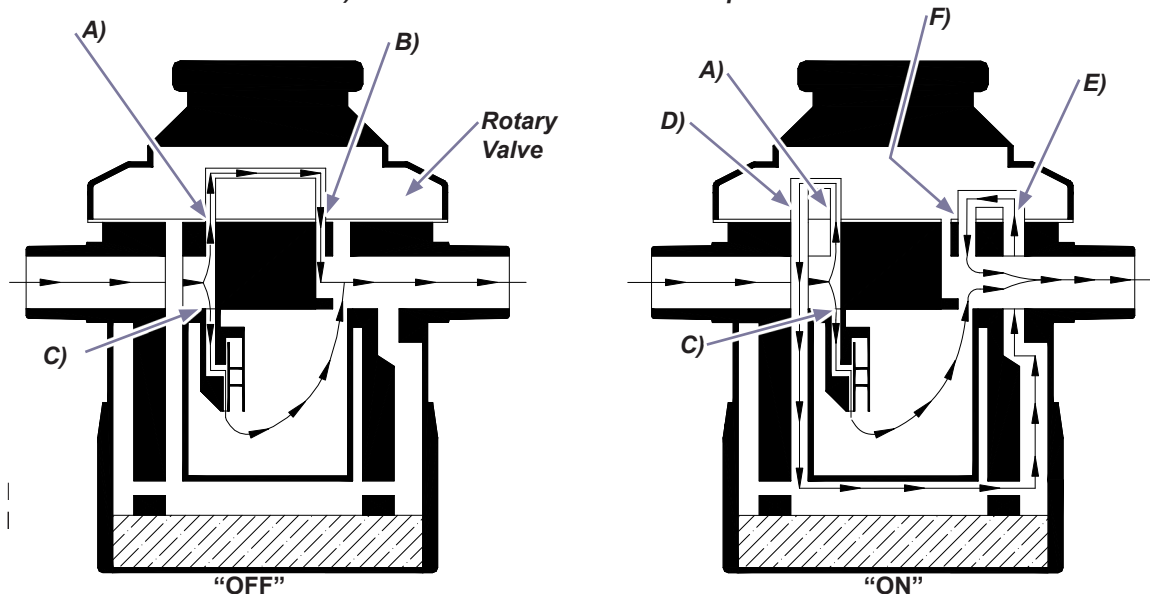

The saturated vapor leaves the chamber outlet via the outlet (E) to the outer channel. This annular channel forms a variable resistance pathway, which controls the concentration of vapor. The channel is of uniform width throughout its length, but with an increase in depth from beginning to end.

The saturated vapor leaves the channel at the outlet (F) and passes to the vaporizer outlet to mix with the bypass gas to form the final outlet concentration. To increase concentration, the dial is rotated counter-clockwise so that inlet (E) and outlet (F) move relatively down to a deeper part of the calibrated channel so that the flow resistance between (E) and (F) falls. It will be seen that counter-clockwise rotation of the dial control (rotary valve) results in a lower vapor chamber resistance, thus a greater proportion of the total gas flow passes through the vaporizing chamber, which results in a rise in outlet concentration.

Principle of Operation *continued...*

Operation Schematic *continued...*

As the VIP 3000 calibrated vaporizer has a long inlet pathway, this, coupled with similar volumes of bypass vapor and a small volume vaporizing chamber, means that it is not readily susceptible to a pumping effect. The vaporizer's high resistance means that it can be used **ONLY BEFORE** the patient circuit. Should the temperature fall, the thermostat moves toward closed and more gas is diverted into the vaporizing chamber.

Installation



WARNING

Keep the VIP 3000 calibrated vaporizer upright at all time. Do not carry the vaporizer by holding the dial control. To help minimize administering multiple agent anesthesia to the patient, only one VIP 3000 calibrated vaporizer should be fitted to an anesthesia machine at any one time.

The VIP 3000 calibrated vaporizer must always be mounted between the flow-metering unit and the patient breathing circuit, but upstream of any absorber or humidifier.

Check the integrity of the fittings to ensure that they are leak tight. If in doubt, seek advice from the manufacturer of the equipment to which the vaporizer is attached.

Unless otherwise specified, all VIP 3000 calibrated vaporizers are supplied as standard with 23-mm cagemount fitting inlet and outlet ports.

Mounting the Vaporizer

Cagemount fitted vaporizers normally have the standard 23-mm tapered ports: male (inlet) on the left and female (outlet) on the right when viewed from the front. There are two threaded holes at the rear of the vaporizer, which are utilized to secure the vaporizer onto the anesthesia machine using appropriate studs, spacers, and nuts.

For Cagemount fitted Vaporizers...

- A) Lightly coat the tapers with oxygen-safe grease such as Krytox.*
- B) Push the tapered fittings fully onto the appropriate tapers.*



WARNING

Ensure that all connections are gas tight before using the machine. Before use, ALL connections must be checked for leaks and functional tests must be performed as described in the anesthetic machine user manual. As there is no interlock fitted to the VIP 3000 calibrated vaporizers, only one vaporizer should be connected at any one time, thus assisting with the prevention of administering multiple agent anesthesia to the patient.

Operating Instructions



WARNING

*Ensure that the VIP 3000 calibrated vaporizer is upright at all times.
Do not carry the VIP 3000 calibrated vaporizer by holding the dial control.*

To Turn the Vaporizer ON...

Depress the dial control release button and turn the dial in a counter-clockwise direction. To avoid inadvertent delivery of small concentrations of agent, the dial control must be turned to "OFF" when the vaporizer is not in use.

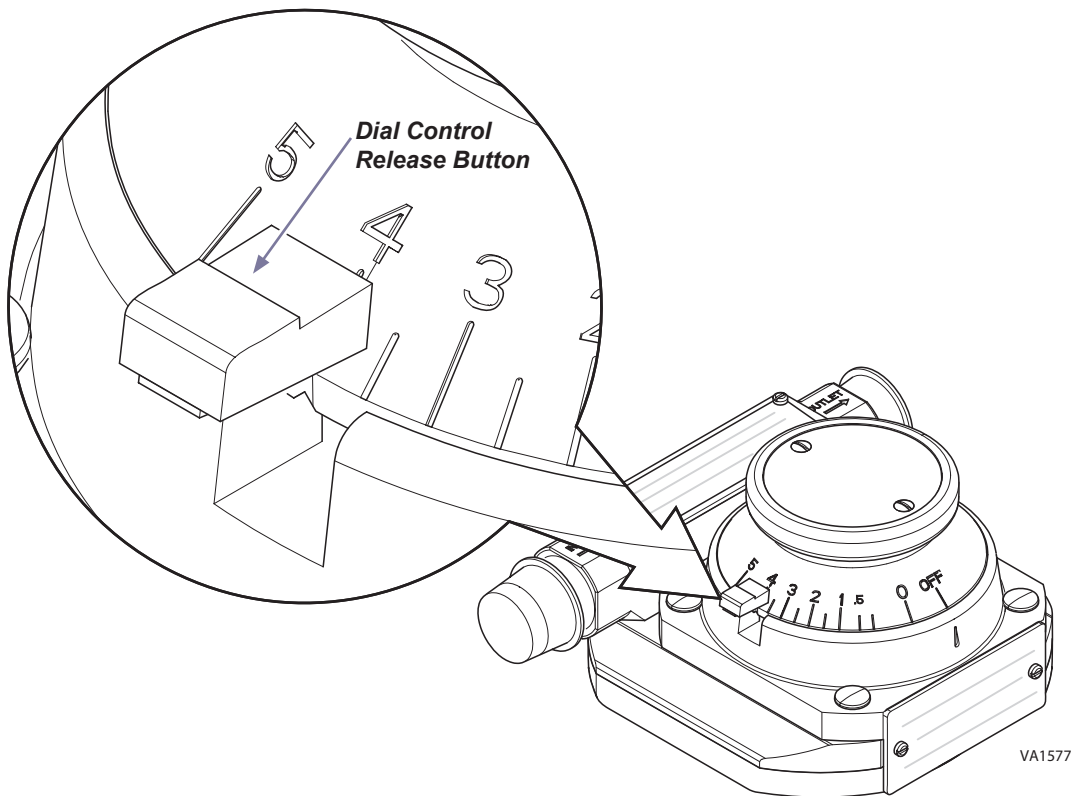

Operating Instructions *continued...*

Filling and Draining

General



WARNING

- **Do not fill the vaporizer with any agent other than the one specified on the front label. The vaporizer is designed for that agent only. Use of any agent other than the one specified can be dangerous to the patient.**
- **Do not fill the vaporizer unless the dial control is in the “OFF” position.**
- **Do not turn the dial “ON” during filling, or attempt to fill the vaporizer beyond the full mark.**
- **Do not drain the agent into any container other than a properly marked container.**
- **Periodically check the agent level. The VIP 3000 calibrated vaporizer must be filled at appropriate intervals. The vaporizer functions satisfactorily as long as the agent is above the minimum level mark on the agent level indicator.**
- **The VIP 3000 calibrated vaporizer must be filled and used in an upright position.**

Filling Well-Fill Models

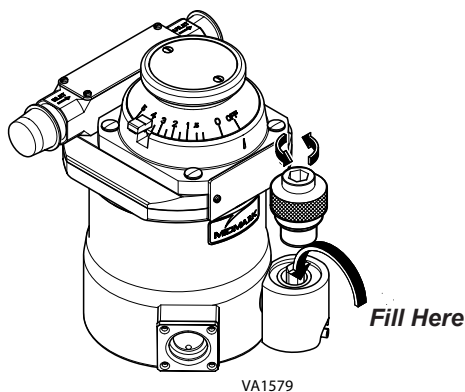

Caution

The vaporizer may be pressurized. Turn the screw cap slowly when filling or draining vaporizers which are filled with screw cap fillers.

Filling Procedure...

- A) Ensure that the Dial is in the “OFF” position. Remove the screw cap.
- B) Verify the agent to be used is the same as that specified on the front of the vaporizer. Pour the agent slowly into the filler opening, observing the agent level through the agent level indicator.

Note: If the vaporizer was dry before filling, the level will decrease slightly as the wicks absorb the agent.

- C) When the agent level reaches the maximum level mark on the agent level indicator, the vaporizer is full. Replace the screw cap by turning it clockwise. To prevent leakage, ensure that the screw cap is fully tightened.

Operating Instructions *continued...*

Draining Well-Fill Models



Caution

Ensure the dial control is in the "OFF" position.

The vaporizer may be pressurized. Unscrew the screw cap slowly.

Draining Procedure...

A) Turn the screw cap counter-clockwise, remove cap to reveal the drain plug.

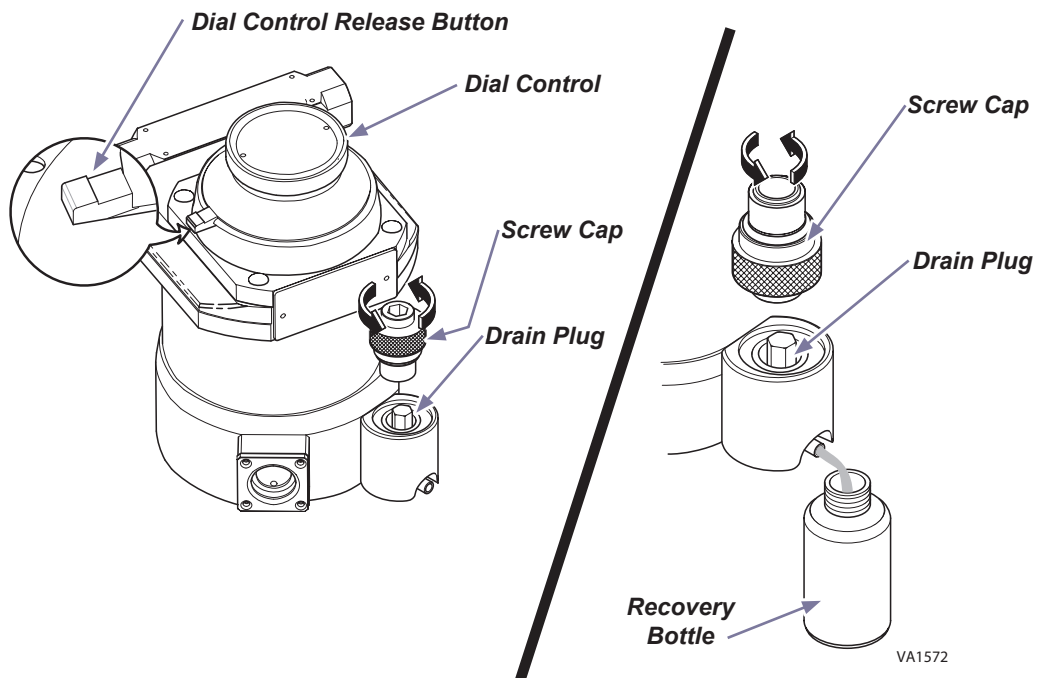

Warning

After draining the unit, fully, tighten the drain plug before replacing the screw cap.

Do not drain the agent into any container other than a properly marked container.

Draining Procedure CONTINUED...

- B) Invert the screw cap and use the slot or hex (depending on model) in the top to engage the drain plug.
- C) Turn inverted screw cap counter-clockwise to loosen the drain plug. Remove the drain plug. Drain the agent into a properly marked recovery bottle for disposal.
- D) Invert the screw cap and tighten securely into the fill-well.

Operating Instructions *continued...*

Filling Key-Filled Models

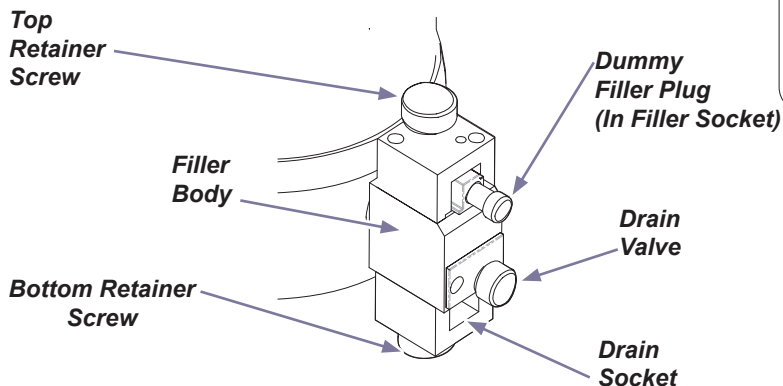

Note

This filling system consists of three key elements, as follows: The anesthetic agent bottle collar, bottle adapter and the filling/draining unit fitted to the vaporizer.



Caution

The vaporizer may be pressurized. Turn the top retaining screw slowly when removing the dummy filler plug on vaporizers fitted with key filled.

Key Filled - Filling Procedure...

A) Remove the cap and seal from the anesthetic bottle. Check that the bottle neck is not chipped or damaged. Fit the keyways of the bottle adapter to the keys of the bottle collar. Screw them together until fully tightened. The bottle is then ready for filling the vaporizer

Note: Only the correct agent-specific adapter can be fitted into the matching filler socket.

B) Ensure that the dial control is set to the "OFF" position. Turn the top retaining screw on the filler unit counter-clockwise and withdraw the dummy filler plug.

C) Hold the bottle upright below the filler socket and bend the adapter so that its end is horizontal and the two holes in the adapter are facing downwards. Insert the adapter into the filler socket.

D) After insertion, turn the top retaining screw clockwise to tighten it and seal the filler adapter in the filler socket.

E) Raise the bottle above the level of the filler socket, avoiding kinking the adapter tube. A steady stream of bubbles should emerge from the adapter inner tube within two seconds. If this does not occur, remove the bottle and adapter from the vaporizer and remove the adapter from the bottle. Carefully shake the adapter two or three times to clear the tube, then repeat steps A thru E.

F) When the vaporizer is filled to the maximum level mark in the agent level indicator, lower the bottle below the level of the filler socket and wait for five seconds to allow any agent in the adapter to drain back into the bottle, then unscrew the top retaining screw and remove the adapter from the filler. If there is any excess liquid agent, allow this to escape from the filler socket completely, then insert and fully tighten the dummy filler plug to prevent gas from escaping through the filler. The VIP 3000 calibrated vaporizer is now ready for use.

Note: If the vaporizer was dry before filling, the level will decrease as the wicks absorb the agent.

Operating Instructions *continued...*

Draining Key-Filled Models



Caution

Ensure the dial control is in the "OFF" position, that the recovery bottle is below the drain socket and that the adapter tube is not kinked. Only the correct agent-specific adapter will fit into the matching drain socket.

Draining Procedure...

- A) Remove cap from recovery bottle. Align keyways of bottle adapter into keys of bottle collar and fully tighten.
- B) Insert bottle adapter into the drain socket with the two holes facing upward then tighten bottom retaining screw.

Continue Draining Procedure on Next Page...

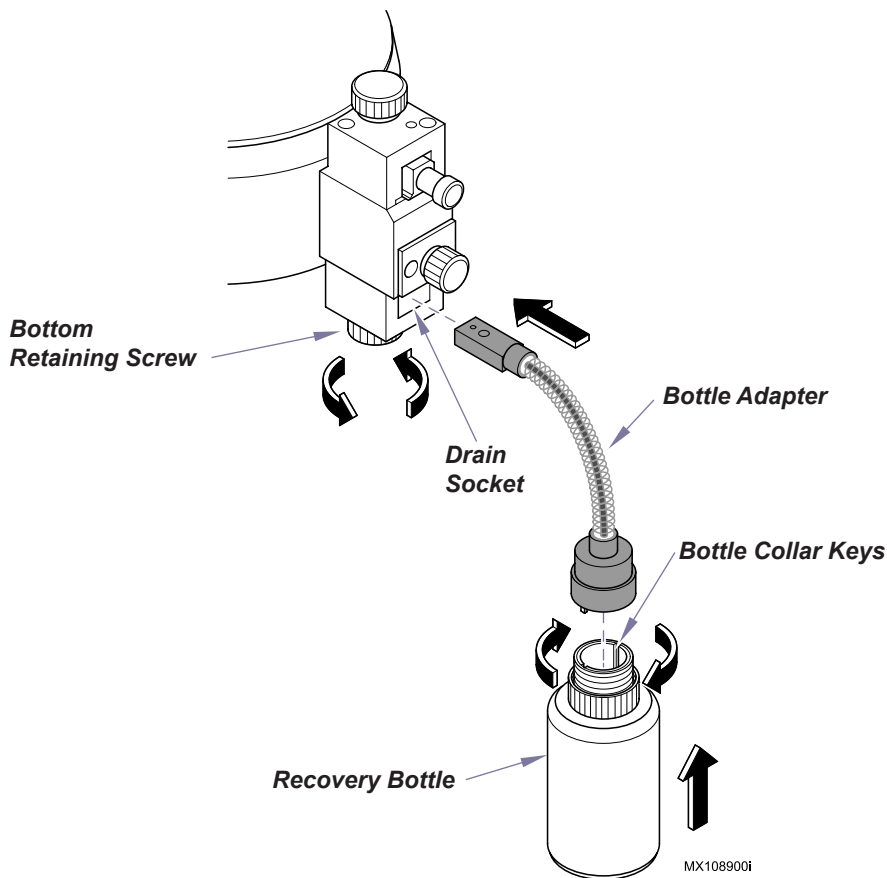

Operating Instructions *continued...*

Draining Key-Filled Models

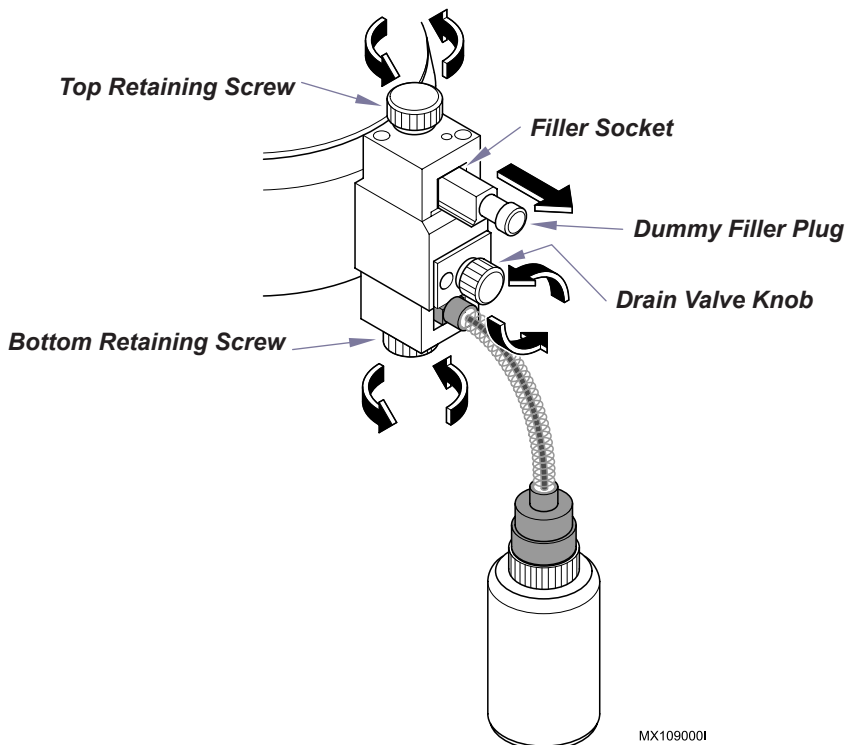

Caution

The vaporizer may be pressurized, unscrew the top retaining screw slowly.

Draining Procedure CONTINUED...

- C) *To allow air to vent, unscrew the top retaining screw and remove the dummy filler plug from the filler socket.*
- D) *Open the drain valve by turning knob counterclockwise to initiate the agent draining process.*
- E) *When draining has been successfully completed, reverse steps A thru D.*

Note

If it is not possible to complete the draining process, close the drain valve, loosen the bottom retaining screw, remove the bottle and adapter from the vaporizer then remove the adapter from the bottle. Carefully shake the adapter two or three times to clear the tube, then repeat steps 1 through 4.

Checking Calibration

General

The performance of the VIP 3000 calibrated vaporizers, which are in clinical use, is monitored by observing patient signs and consumption of anesthetic agent. Some users may, however, wish to employ analyzers to determine whether any abnormalities of performance have developed.

The following points must be considered when any measurements are being carried out on a VIP 3000 calibrated vaporizer to determine whether any abnormalities of performance have developed.

- 1. In order to predict the concentration that the VIP 3000 calibrated vaporizer can be expected to deliver, the detailed nominal performance data and the preceding comments should be noted.**
- 2. The method of testing used should be representative of normal conditions of use.**
- 3. Any sampling techniques should be such as to ensure the following:**
 - a. The sample is fully representative of the vaporizer output, which may not be a homogeneous mixture at the vaporizer outlet.**
 - b. Absorption of agent by any connecting tubing is negligible.**
- 4. If a number of vaporizers are being examined simultaneously, the probability of them all being consistently in error is so remote as to be negligible and the cause of any apparent error is likely to lie in the employed method of testing.**
- 5. Consistent and reproducible analytical techniques should be used.**
- 6. If unexpected results are obtained, it is a wise precaution to repeat the observations, since the VIP 3000 calibrated vaporizer may be more reliable than the techniques used to observe its performance.**
- 7. If unexpected results occur, it is also worthwhile to check for sources of error, e.g. flow meter leaks, absorption by adjacent components, etc...**
- 8. Full account should be taken of any extraneous effects on the analyzer, which may arise from changes in carrier gas composition.**
- 9. If the anesthetic machine on which the VIP 3000 calibrated vaporizer is fitted is left for a period of time with no gases flowing, sensitive analyzers may detect small concentrations of agent for a short time at the machine outlet after the machine is turned "ON" with the vaporizer turned "OFF". This concentration can be expected to decrease rapidly to zero within approximately 15 seconds at 5 liters per minute. This phenomenon is a normal characteristic of anesthetic vaporizers and anesthetic machines.**
- 10. At the zero or "OFF"- setting (where marked), it is not abnormal for small steady concentrations to be observed when using sensitive analyzers.**

Checking Calibration *continued...*

Analytical Techniques

For field checking of the state of calibration, many techniques and analyzers are available. Midmark does not recommend any one technique or analyzer, but account must be taken of errors of use and calibration of analyzers. The reliability of both must be realistically considered.

The following method of checking may be used where special equipment is not available and a secondary check on analyzers is desirable. The characteristics of the vaporizer are such that if the vaporizer is satisfactory at one dial setting it should be satisfactory at all graduation settings.



WARNING

Appropriate measures to handle exhaust gases and spillage should be carried out during this test.

1. Ensure that the vaporizer is full and has remained at an ambient temperature of 67°F to 73°F (19.4°C to 22.7°C) for a minimum period of 3 hours.
2. With the vaporizer securely mounted, remove the drain valve until no more liquid agent runs out. Replace and tighten the drain valve.
3. With the dial set at “OFF”, carefully and quickly refill the vaporizer with a measured amount of agent (approximately 70 milliliters) without spilling. Close the screw cap securely.
4. Ensure that the temperature has stabilized. Allow the vaporizer to remain at 67°F to 73°F (19.4°C to 22.7°C) for one hour.
5. Set the flow rate to 4 liters per minute O₂.
6. Note the time, turn the dial to 2% and check that the flow rate remains at 4 liters per minute, readjust if necessary.
7. Leave the vaporizer at this setting for 30 minutes, periodically checking and adjusting the flow rate if necessary.
8. Drain as described in Section 7.0. Measure the amount of liquid drained from the vaporizer.
9. The amount of liquid consumed should be as follows:
 - a. Isoflurane 12.3 milliliters
 - b. Sevoflurane 13.2 milliliters

It should be appreciated that the preceding method of checking is designed to be quick and easy under ordinary hospital conditions and that the method is somewhat imprecise. Nevertheless, it would be unusual for measured liquid agent consumption to vary by more than approximately 25% from the amounts shown above.

Maintenance



WARNING

- *Do not modify, tamper with, or disassemble the VIP 3000 calibrated vaporizer.*
- *If the vaporizer is modified in any way there could be possible danger of damaging the unit and altering the accuracy of output concentration.*
- *Do not immerse the VIP 3000 calibrated vaporizer in any liquid, including water.*
- *Do not sterilize the VIP 3000 calibrated vaporizer.*

Schedule

Every Two Weeks

When the level is low, the contents of the VIP 3000 calibrated vaporizer should be drained into an appropriately marked container. Discard the agent in a locally approved manner. Agents such as Isoflurane and Sevoflurane require less frequent intervals since they do not contain any additives or stabilizing agents.

Annually

The VIP 3000 calibrated vaporizer should be serviced annually at a Midmark authorized Service Center.

This service includes the following:

1. Complete disassembly of the vaporizer and its components.
2. Thorough cleaning.
3. Inspection for damage and wear.
4. Renewal of wicks, seals and any damaged, worn or outdated components.
5. Lubrication where necessary.
6. Checking the delivered vapor concentration under closely defined conditions. Re-graduation and adjustment where necessary.

Maintenance *continued...*

Cleaning



WARNING

Do not put water or another solvent in the VIP 3000 calibrated vaporizer. A vaporizer should be filled with the specified anesthetic agent only.

Clean the exterior of the VIP 3000 calibrated vaporizer with a damp cloth.

Never allow cleaning agents to accumulate in the filler or gas inlet and outlet ports, or around the dial control.

Contamination

If any liquid other than the correct agent is put into the VIP 3000 calibrated vaporizer:

1. Drain and discard all the liquid.
2. Set the dial control to maximum concentration and flush the vaporizer with 4 liters per minute oxygen until no trace of the contaminant can be detected.
3. Allow 2 hours to elapse for the vaporizer temperature to stabilize. Test the vaporizer to ensure that no trace of contaminant is present.

If the contaminant is not volatile (e.g. water), drain the vaporizer and return it to a Midmark authorized Service Center.

Repairs and Returns

Repairs should only be carried out by Midmark authorized service representatives or agents.
Return Goods Procedure

All returns must be made through an authorized dealer. Units for repair should be sent to Midmark and packaged in the original shipping container if possible. Please contact our Customer Service Department at 1.800.Midmark (1.800.643.6275), prior to shipping the unit prepaid to receive authorization RMA number. Specify the RMA number on the outside of the box and label it to the attention of Repair Service Center.

Ship to:

Midmark Corporation
Plant A Returns Dept
Attn: Repair Service Center
60 Vista Drive
Versailles OH 45380

Warranty Information

<https://www.midmark.com/service-support/terms-conditions>



Warranty Registration

<https://www.midmark.com/service-support/terms-conditions/warranty-registration>



Midmark Corporation

60 Vista Drive
Versailles, OH 45380 USA
1.800.643.6275
1.937.526.3662
midmark.com

