



Midmark Digital Vital Signs Device

Version 10.0



Notice

The information in this manual is subject to change without notice.

Midmark Corporation shall not be liable for technical or editorial omissions made herein, nor for incidental or consequential damages resulting from the furnishing, performance, or use of this guide.

This document may contain proprietary information protected by copyright. No part of this document may be photocopied or reproduced in any form without prior written consent from Midmark Corporation.

IQecg, IQholter, IQmanager, IQpath and Barrier-Free are trademarks of Midmark Corporation.

Microsoft and Windows are registered trademarks of Microsoft Corporation in the United States and other countries.

Intel and Intel Core are trademarks of Intel Corporation in the United States and other countries. Alaris and Turbo

Temp are registered trademarks of CareFusion Corporation.

UltraCheck is a registered trademark of Statcorp Medical, a division of OSI Optoelectronics Company. Fairbanks and TeleWeigh are trademarks of Fairbanks Scales, Inc.

ENZOL, CIDEZYME, and CIDEX are registered trademarks of Advanced Sterilization Products, Division of Ethicon Inc., a Johnson & Johnson company

Part number for this Operation Manual: 21-78-0001 Rev DA1



Caution

Federal Law restricts this device to sale by or on order of a physician or properly licensed practitioner.

Table of Contents

I. Introduction	5
II. Product Overview and General Information	5
A. Intended Use.....	6
B. Warnings.....	6
C. Cautions.....	7
D. System Specifications.....	9
III. Minimum Computer Requirements	11
IV. Symbols	12
V. Device Unpacking and Initial Setup	14
A. Contents Checklist.....	14
B. Initial Device Set Up.....	15
VI. Power the Device	19
A. AC Power Transformer.....	19
B. Battery	19
C. Power-Up Screens.....	19
VII. Main Testing Screen	20
A. Buttons and Icons	20
B. Display of Data	22
C. Manual Entry of Data	23
D. BMI Calculation.....	23
E. Time.....	23
F. Table Scale.....	23
G. Save Button.....	24
H. Using the Memory Button and Password	24
VIII. Device Operation	26
A. Blood Pressure	26
B. Temperature	29
C. Pulse Oximetry Operation (SpO ₂)	33
D. Scale Operation	34
E. Printer Operation	38
F. Manual Entry of Information	39
G. Pain Scale.....	39
IX. Additional Functionality and Settings	40
A. Settings Button and Password.....	40
B. Changing Blood Pressure Inflation Settings	41
C. Memory Setting Button.....	42
D. Monitor Settings Button	44
E. Setting Changes via the More button	46
F. Additional Setting Changes and Options from the More Button.....	48
X. Error Codes and Corrective Actions	58
XI. Cleaning of Midmark Digital Vital Signs Device and Accessories	61
XII. Maintenance, Storage and Battery Replacement	63
A. Maintenance	63
B. Storage	64

C. Battery Replacement	64
XIII. Appendix A - Configuring a Midmark Digital Vital Signs Device with the Midmark Integrated Scale	65
XIV. Customer Support and Warranty Information.....	69
Warranty.....	69
Return Materials Authorization	69
Shipping	69
XV. Disposal	70
XVI. Accessories and Supplies	71
XVII. Electromagnetic Compatibility (EMC) Information.....	72
XVIII. Contact Information	76

I. Introduction

This operation manual is a comprehensive guide, designed to educate the user on the operation and functions of the Midmark Digital Vital Signs Device. The information in this manual includes all options that are available with the Midmark Digital Vital Signs Device, such as SpO₂, external printer, and scale. The manual may contain information about functions that are not included with all devices.

II. Product Overview and General Information

Midmark Digital Vital Signs Device automatically and noninvasively measures systolic and diastolic blood pressure, pulse rate, temperature (oral or axillary), and oxygen saturation (SpO₂) for adult and pediatric patients. All functions of the device are performed via the touch screen display, except the on/off function which is a separate button on the front of the device.

Note

Midmark Digital Vital Signs Device is not intended for use on neonatal patients.

Note

For accuracy and safety in pediatric blood pressure measurements, the smallest cuff approved for use on infants and small children is the Infant (#3-009-0068). It is important that the child's arm fits within the range markings on the cuff

Midmark Digital Vital Signs Device has a rechargeable lithium ion battery and four mounting options: a mobile cart, a countertop mount, a wall mount, and an IV pole mount.

All vitals parameters can be simultaneously measured and are easily viewed on the touch screen display.

Note

Midmark Digital Vital Signs Device is not intended for continuous monitoring of patients or for use during patient transport.

Temperature is measured at oral and axillary sites.

A. Intended Use

The Midmark Digital Vital Signs Device is intended to be used by clinicians and medically qualified personnel for measuring adult and pediatric patients for noninvasive blood pressure, pulse rate, noninvasive functional oxygen saturation of arterial hemoglobin (SpO₂), temperature, and weight.

Patient information, such as name, age, height, pain score, etc., can be entered manually.

B. Warnings



WARNING

Do not use this device for any purpose other than its specified intended use.



WARNING

Midmark Digital Vital Signs Device is not intended for continuous monitoring. Do not leave a patient unattended while taking measurements with this device.



WARNING

Midmark Digital Vital Signs Device is not intended for use during patient transport.



WARNING

To ensure patient safety, only use supplies and accessories that are supplied with the Midmark Digital Vital Signs Device and recommended by Midmark. Using unapproved accessories can affect patient and/or operator safety.



WARNING

Regularly inspect the blood pressure cuff, SpO₂ cable, and other accessories for damage. Replace accessories as needed.



WARNING

Midmark Digital Vital Signs Device is not intended to be hand-held during operation.



WARNING

Do not connect more than one patient to the device at the same time.



WARNING

Do not route the cables of the device in a way that they may present a stumbling hazard.



WARNING

Midmark Digital Vital Signs Device is not intended for use in the following cases:

- *neonatal patients*
- *apnea monitoring*
- *in a magnetic resonance imaging (MRI) environment*
- *in an electro-static unit (ESU) environment*
- *applications requiring arrhythmia detection*



WARNING

FLAMMABLE ANESTHETICS: An explosion hazard exists if the monitor is used in the presence of flammable anesthetics.

**WARNING**

BLOOD PRESSURE MEASUREMENT: Avoid frequent and prolonged blood pressure measurements, which can result in petechia, ischemia, purpura or neuropathy. In addition, be sure that the blood pressure hose does not become kinked during a measurement. If left unattended, this could result in sustained pressure in the blood pressure cuff.

**WARNING**

BATTERY HANDLING: Midmark Digital Vital Signs Device contains a lithium ion battery. The following precautions should be taken regarding these batteries:

- Do not immerse in water.
- Do not heat or throw in fire.
- Do not leave in conditions over 140°F (60°C) or in a heated car.
- Do not attempt to crush or drop.
- Only use the battery with the Midmark Digital Vital Signs Device.
- Follow the instructions in the [Disposal](#) section of this manual when the Midmark Digital Vital Signs Device is taken out of service.

C. Cautions

Review the following information to avoid damage to the device and to ensure proper operation:

**Caution**

Familiarize yourself thoroughly with the operational procedures of the device prior to use.

**Caution**

Substitution of components different from those supplied could result in measurement error.

**Caution**

Do not operate the Midmark Digital Vital Signs Device near high frequency emissions (e.g. microwaves).

**Caution**

The Midmark Digital Vital Signs Device is intended for indoor use only.

**Caution**

The device and its accessories are not intended to be sterilized by any method. Attempting to do so may permanently damage the equipment.

**Caution**

Electronic devices can be damaged by exposure to liquids. Do not use or store the Midmark Digital Vital Signs Device near any type of liquids.

**Caution**

In case of malfunction, contact [Midmark Technical Service](#) and be prepared to describe the problem.

**Caution**

To ensure proper operation, perform routine inspection and maintenance on the device. See [Section XII, Maintenance, Storage and Battery Replacement](#).

**Caution**

Do not make any modifications to the device. Any modifications made will void the warranty.

**Caution**

Refer servicing to qualified personnel.

**Caution**

ARRHYTHMIA PATIENTS: The Midmark Digital Vital Signs Device is designed to operate in the presence of cardiac arrhythmias, however, NIBP readings, and parameters derived from it, may be inaccurate for patients experiencing moderate to severe arrhythmia.

**Caution****BLOOD PRESSURE MEASUREMENT**

- Do not allow the blood pressure cuff or hose to come into contact with fluids. If this occurs, See [Section XI, Cleaning of Midmark Digital Vital Signs Device and Accessories](#) of this manual for drying instructions.
- Check the hose and cuff frequently for signs of damage or debris. An obstruction in the hose may interfere with inflation and deflation, resulting in inaccurate readings.
- To obtain accurate blood pressure readings, keep the limb and the cuff motionless.
- The blood pressure cuff should be at the same level as the patient's heart. If you cannot place the blood pressure cuff at this level, add 1.4 mmHg to the measured pressure values for each 2 cm above the heart level, or subtract 1.4 mmHg for each 2 cm below heart level.
- Blood pressure measurements may not be accurate if the patient is convulsive or experiencing tremors.
- Check for kinks in the blood pressure hose if the device reports a measurement problem.



Caution

PULSE OXIMETRY MEASUREMENT (SpO₂)

- Read instructions provided with the sensor to understand the best application technique and all relevant safety information.
- Do not apply the sensor on the same limb as the blood pressure cuff. During blood pressure measurements, the perfusion is temporarily reduced, which can result in inaccurate pulse oximetry readings.
- Refer to [Section XVI, Accessories and Supplies](#) for approved SpO₂ sensors.
- Elevated levels of carboxyhemoglobin or methemoglobin can result in inaccurate pulse oximetry readings.
- Bright light can create problems with the pulse oximetry measurements, resulting in inaccurate readings. If the sensor is in a place where it may be exposed to bright light, you should cover it with some opaque material.
- Pulse oximetry readings may be inaccurate in the presence of excessive motion artifact or tremors.

D. System Specifications

General Performance	
Category	Specifications
Product Name	Midmark Digital Vital Signs Device
Product Type	Non-invasive, multi-parameter Midmark Digital Vital Signs Device
Product Weight	3.9Lbs. (1.77kg)
Product Dimensions	10.5"L X 4"W X 7"H (.27x.10x.18 m)
Power Requirements	Input: 100 – 240V ~ / 50 – 60Hz / 700mA Output: 15V / 2A
Battery Requirements	<ul style="list-style-type: none"> • Battery Type: Rechargeable, 10.8 V lithium ion • Low Power Indicator • Automatic Shutdown on low power • Operating Time: Approximately 8 hours • Leakage current: Meets AAMI/IEC/CSA 60601-1 requirements • Battery charge time: 4 hours to fully charge, 3 hours for 95% charge
Type of Protection (Electrical)	Class II
Degree of Protection (Water)	IPX1
Disinfecting Method	Per the instructions in the Cleaning of Midmark Digital Vital Signs Device and Accessories section of this manual
Degree of Safety (Flammable Anesthetic Mixture)	Not suitable for use in the presence of a Flammable Anesthetic Mixture
EMC Standard	Per IEC 60601-1-2 and FCC Part 15 (Emissions Class B)
Device Connectivity	USB (Client)
Accessory Connectivity	USB 1.1 (Master)

Environmental	
Category	Specifications
Cooling	Convection (no fan)
Operating Temperature	32 to 104 °F (0 to 40 °C) {For Patient Temperature Measurement: 61 to 91°F (16 to 33°C)}
Storage Temperature	-4 to 140 °F (-20 to 60 °C)
Operating Humidity	15 to 90% non-condensing
Storage Humidity	15 to 95% non-condensing
Operating Altitude	0 to 15,000 feet
Storage Altitude	0 to 40,000 feet
Non-Invasive Blood Pressure	
Category	Specifications
Method	Oscillometric
Cuff	Infant, Child, Small Adult, Adult, Adult Long, Large Adult, Large Adult Long, and Thigh
Derived Parameters	Systolic, Diastolic, and Mean Arterial Pressure (MAP)
Measurement Range	<ul style="list-style-type: none"> • Systolic: 30 to 250 mmHg • MAP: 20 to 230 mmHg • Diastolic: 10 to 210 mmHg
Measurement Accuracy	<ul style="list-style-type: none"> • Systolic: ±5mmHg • MAP: ±5mmHg • Diastolic: ±5mmHg
Pulse Rate Range	30 to 240 BPM
Pulse Rate Accuracy	±5% or ±2 BPM, whichever is greater
Initial Cuff Pressure	User-Selectable
Overpressure Cutoff	290 ± 3 mmHg (normal means), 300 ± 30 mmHg (back-up)
Measurement Time	Approximately 30 seconds
Temperature	
Category	Specifications
Probe Type	Alaris® Turbo Temp™
Scale	<ul style="list-style-type: none"> • Fahrenheit (F) • Celsius (C)
Measurement Type	Oral and Axillary
Measurement Range	<ul style="list-style-type: none"> • Oral: 95 to 106°F (35 to 41°C) • Axillary: 95 to 106°F (35 to 41°C)
Measurement Accuracy	±0.2°F (±0.1°C)
Measurement Time	<ul style="list-style-type: none"> • Predictive Oral: 8-10 seconds • Axillary: 13-20 seconds

Pulse Oximetry (SpO ₂)	
Category	Specifications
Method	Absorption – Spectrophotometric (dual wavelength) (Functional oxygen saturation of arterial hemoglobin)
SpO ₂ /PR Resolution	<ul style="list-style-type: none"> • SpO₂: 1 O₂% • PR: 1 BPM (beat per minute)
Measurement Range	<ul style="list-style-type: none"> • SpO₂: 20 to 100% • PR: 30 to 240 BPM
Measurement Accuracy	<ul style="list-style-type: none"> • SpO₂: from 70 to 100%: ±2% (O₂%), < 70%: unspecified • PR: ±5%
Report Interval	1 second

III. Minimum Computer Requirements















The versatility of the Midmark Digital Vital Signs Device allows for it to be used with or without connection to a computer. If using the Midmark Digital Vital Signs Device with a computer, refer to the *Minimum Computer Requirements* document at www.midmark.com, or contact [Midmark Technical Service](#).



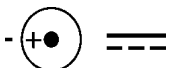



Note

The Midmark Digital Vital Signs Device requires software when operating with a PC. Please contact Midmark at 1.844.856.1230, option 2 to purchase the required software license.

IV. Symbols

The following symbols are associated with Midmark Digital Vital Signs Device.

Symbol	Description
	Follow instructions for use.
	Do not dispose of this product as unsorted municipal waste. For more disposal information, see Section XV, Disposal .
	Manufacturer
	Manufacture date
IPX1	Ingress protection against dripping water.
	Patient connections are type BF and protected against defibrillation.
RxOnly	Federal law (U.S.A.) restricts this device to sale by or on the order of a physician
	Blood Pressure
	Temperature Probe Connector
	Power Input: Use Midmark Power Supply (P/N 3-009-0010 or 01-02-0806).
	Power Input: DC connector and connector polarity.
	USB B
	USB
	Scale
	Printer
REF	Catalogue number
SN	Serial number
LOT	Lot code
	Not made with natural rubber latex
	Blood pressure cuff

	Caution
	Consult instructions for use
	Range of humidity to which the medical device can be safely exposed
	Keep dry
	Shipping Direction
	Fragile

V. Device Unpacking and Initial Setup

Before unpacking Midmark Digital Vital Signs Device, inspect the external package for obvious signs of damage. If there are any signs of damage, file a claim immediately with the shipping company.

Contact [Midmark Technical Service](#) immediately to report any product damage and to arrange for repair or replacement of damaged goods.

A. Contents Checklist

The Midmark Digital Vital Signs Device shipping carton contains the items listed below. Upon receipt, check the contents to confirm all items are present. Inspect them for any signs of damage such as dents, cracks, tears, or scratches. If an item is missing or damaged, contact [Midmark Technical Service](#) for a replacement. Depending on the device configuration purchased, not all items listed below will be in the box.

Quantity Each	Description
1	Midmark Digital Vital Signs Device
1	AC Power Supply and Cord
1	Adult Blood Pressure Cuff (26-35 cm)
1	Large Adult Blood Pressure Cuff (32-42 cm)
1	6.5' Blood Pressure Hose
1	Reusable, Adult SpO ₂ Finger Sensor*
1	4' SpO ₂ Extender Cable*
1	Oral/Axillary Temperature Probe
20	Temperature probe covers (one box)
1	USB Cable
1	Operation Manual CD
1	Quick Reference Guide
1	Warranty Card

*Applicable only to devices with the SpO₂ feature (device part number 1-100-1615 / kit product number 4-000-0510).

B. Initial Device Set Up

This section will guide you through the following initial device set up steps:

- Attach accessories
- Charge the battery
- Connect to computer
- Attach scale and printer
- Start the device

Attach Accessories

Attach all accessories to the device before attaching the power cord and turning the power on.

1. Install the temperature probe to its connector located on the back of the device (see **Figure 3**). Thread the temperature probe cord through the temperature cord guide (see **Figure 3**). Insert the temperature probe into its well (see **Figure 1**). Place the box of probe covers (included in the kit) in the probe cover holder of the device (see **Figure 1**).
2. Attach the blood pressure hose to the connector located on the left side of the device (see **Figure 2**). Attach the appropriate size blood pressure cuff to the fitting at the end of the blood pressure hose.
3. Connect the SpO₂ sensor* to the left side of the device (see **Figure 2**). If desired, connect the included SpO₂ extender cable to the sensor. Next, attach the SpO₂ extender cable to the SpO₂ connector on the left side of the device (see **Figure 2**).

*Applicable only to devices with the SpO₂ feature (refer to [Section V-A Contents Checklist](#).)

Charge the battery

1. Attach the power cord to the device (see **Figure 3**). The power input is located on the back of the device. Plug the power cord into the AC wall outlet.
2. It is suggested that the internal battery be fully charged before using the device:
 - Allow approximately four hours to fully charge the battery.
 - The Battery Charge Indicator will flash green when the unit is plugged into AC and the battery is being charged.
 - The Battery Charge Indicator will be a solid green when the battery is fully charged.

Connect to computer

1. If using the Midmark Digital Vital Signs Device with a computer, connect the mini USB connector of the USB cable to the mini USB port on the back of the device and route the cable through the USB cable guide (see **Figure 3**) on the battery door of the Midmark Digital Vital Signs Device. The other end of the USB cable will be connected to an available USB port on the computer.

Attach scale and printer

1. If using a Fairbanks® scale with the Midmark Digital Vital Signs Device, connect the scale cable to the back of the device (see **Figure 3-Scale Interface**). The Midmark Digital Vital Signs Device will automatically detect the scale has been connected and is ready for use.
2. If using a Midmark Exam Chair and Integrated Scale with the Midmark Digital Vital Signs Device, connect the scale cable to the back of the device (see **Figure 3-Scale Interface**). The Table Scale icon will appear to the right of the Clear button on the Main Testing screen when the Midmark Digital Vital Signs Device is configured to the Integrated Scale. See [Section XIII, Appendix A - Configuring an Midmark Digital Vital Signs Device with the Midmark Integrated Scale](#) for complete instructions on configuring the Midmark Digital Vital Signs Device with the Integrated Scale.
3. If using the Midmark Digital Vital Signs Device thermal printer, connect the printer to the back of the device (see **Figure 3-Printer Input**). The device will automatically detect the printer has been connected and is ready for use.

Start the device

1. To start the Midmark Digital Vital Signs Device press the On/Off button located on the front of the device just below the touchscreen (see **Figure 4** below).
 - The On/Off button will illuminate to indicate the device is on.
 - The Battery Charge Indicator will flash green when the unit is plugged into AC and the battery is being charged.
 - The Battery Charge Indicator will be a solid green when the battery is fully charged.

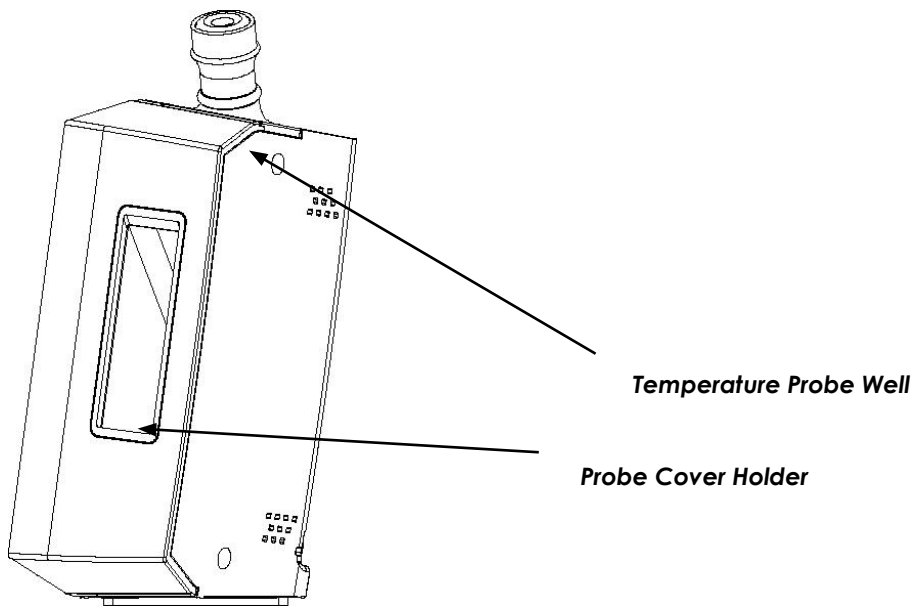

Figure 1

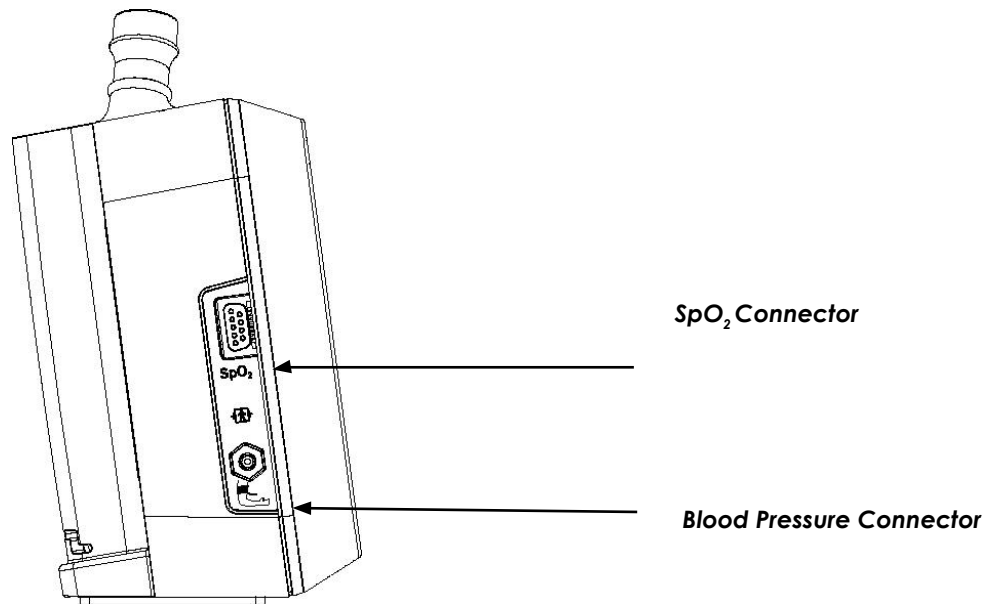

Figure 2

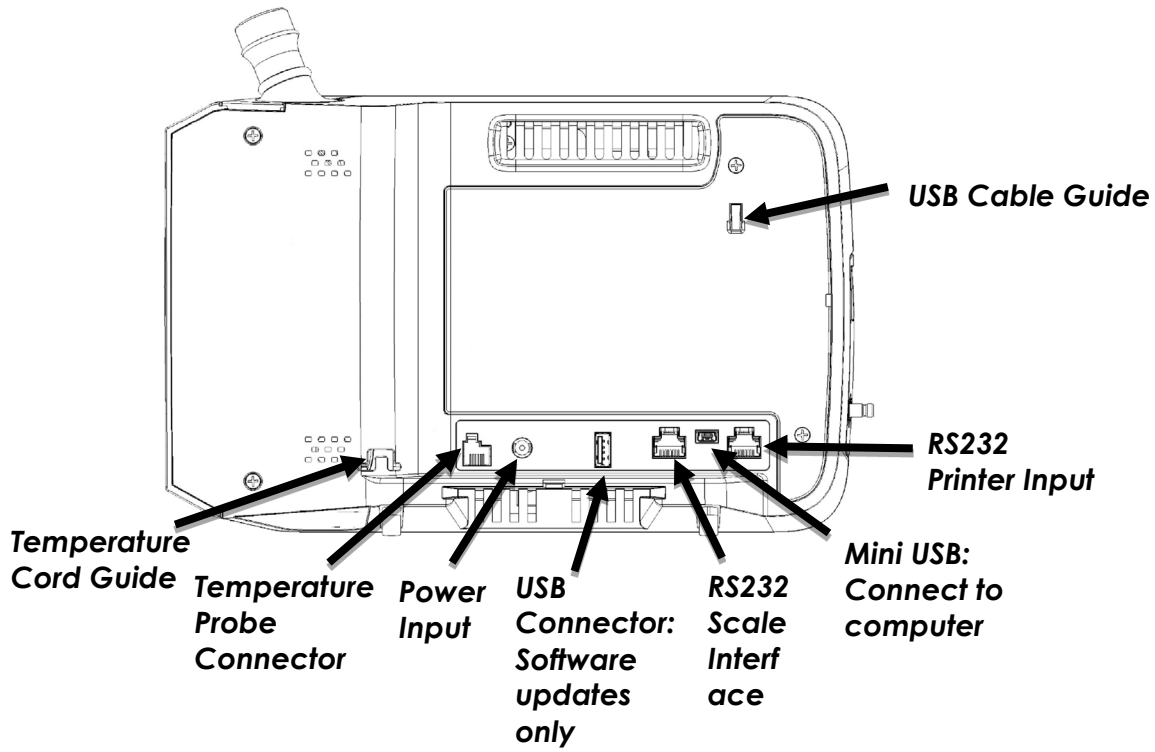

Figure 3

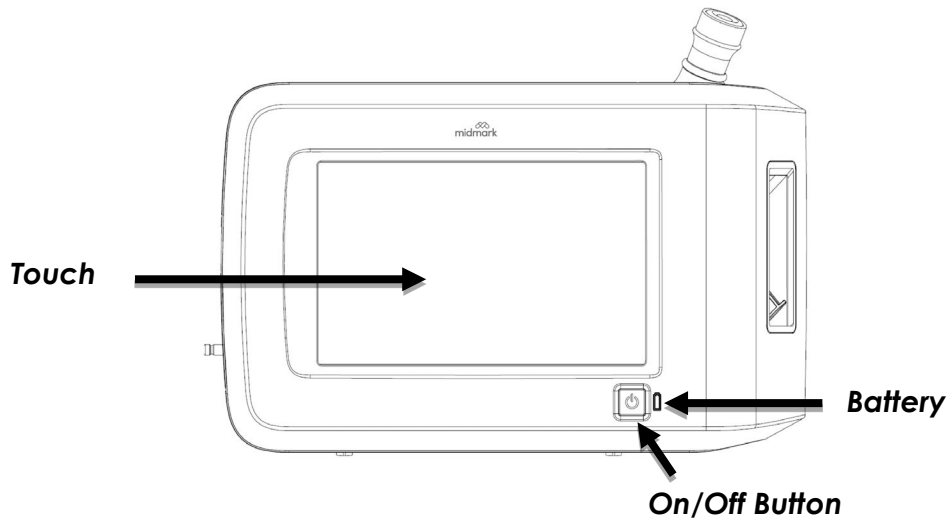

Figure 4

VI. Power the Device

A. AC Power Transformer

The Midmark Digital Vital Signs Device can be run with AC or battery power once the battery has been charged.

- Attach the power cord to the device (see **Figure 3**). The power input is located on the back of the device. Plug the power cord into the AC wall outlet.

B. Battery

- Check the battery level when the device is turned on.
- The device can be operated when the battery is not fully charged.
- It takes approximately four (4) hours to fully charge the battery.
- For optimal battery life, charge the battery before it reaches 20 percent remaining battery power.
- When the battery level gets to approximately 40 percent power, the **Battery** icon on the touchscreen will turn from white to yellow.
 - An initial warning message will appear that states "Battery Low."
 - Connect the device to a wall outlet to recharge the battery.
- When the battery reaches approximately 20 percent power, the **Battery** icon on the touchscreen will change from yellow to red, indicating that the battery level is critically low.
 - An initial warning message will appear that states "Battery Too Low."
 - Connect the device to a wall outlet to recharge the battery.
- For information regarding battery replacement refer to [Section XII-C Battery Replacement](#).

C. Power-Up Screens

The Midmark Digital Vital Signs Device will display two screens before the *Main Testing* screen appears. The Midmark logo screen will appear first, followed by the *Loading Program Settings* notification screen. This screen states that program settings are loading. This screen will be displayed for approximately 25 seconds.

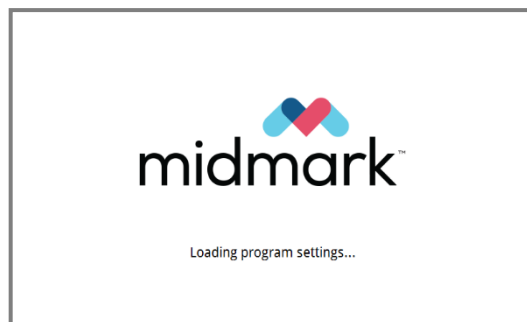

VII. Main Testing Screen

A. Buttons and Icons

- a. Battery charge level
- b. AC power indicator
- c. Table Scale button (see **Note** below)
- d. Memory button
- e. Settings button
- f. Clear button
- g. Save button
- h. Time display
- i. Temperature mode selection
- j. Four blood pressure inflation options

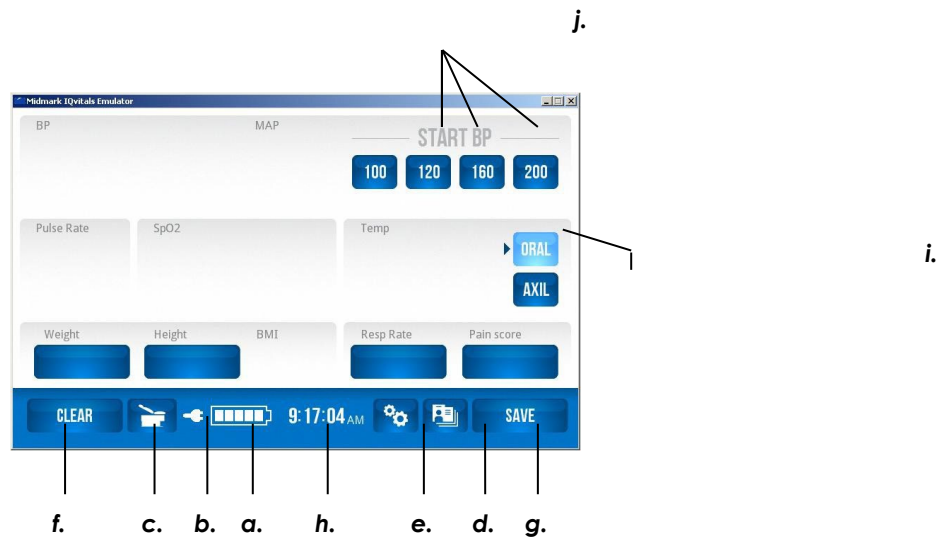

The Midmark Digital Vital Signs Device *Main Testing* screen.

Note

The **Table Scale** icon (item c. in diagram above) will appear to the right of the **Clear** button when the Midmark Digital Vital Signs Device is configured to the Integrated Scale. See [Section XIII, Appendix A - Configuring an Midmark Digital Vital Signs Device with the Midmark Integrated Scale](#) for complete instructions on configuring the Integrated Scale with the Midmark Digital Vital Signs Device.

The **AC power** (plug) and **Battery** icons will be displayed when the unit is plugged in and the battery is charging.



If the unit is not plugged in, the **AC power** icon will not appear, and the battery charge level will be indicated by the number of squares filling the **Battery** icon.

- When the device gets to approximately 40 percent power, a window will appear that says, “Battery low. Connect device to wall outlet to recharge battery.” (This will coincide with the squares in the **Battery** icon turning from white to yellow.)

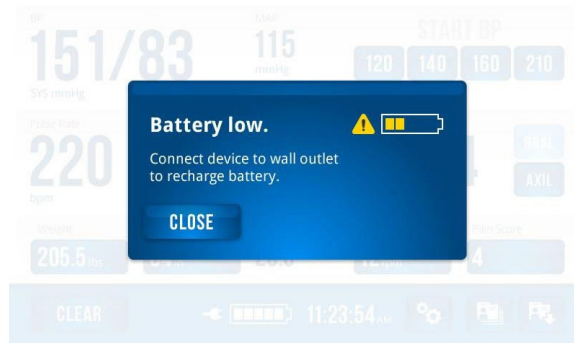

- When the device gets to approximately 20 percent remaining power, a window will appear that says, “Battery too low. Connect device to wall outlet to recharge battery.” (This will coincide with the squares in the **Battery** icon turning from yellow to red.)
- The **Battery** icon outline will also continue to flash between red and white. If the device is not plugged in once the 20 percent warning appears, the device will have approximately 15 minutes before a final message appears that says, “Battery critically low. Power down occurring; connect device to wall outlet to recharge battery.”

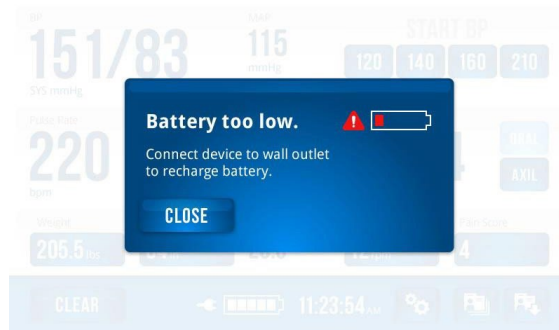

B. Display of Data

The main testing screen has a place to display the following patient data:

- a. Blood pressure
- b. SpO₂
- c. Temperature
- d. Weight
- e. Respiration Rate
- f. Pulse Rate
- g. Height
- h. Pain Score
- i. BMI
- j. MAP
- k. Pulse progress bar

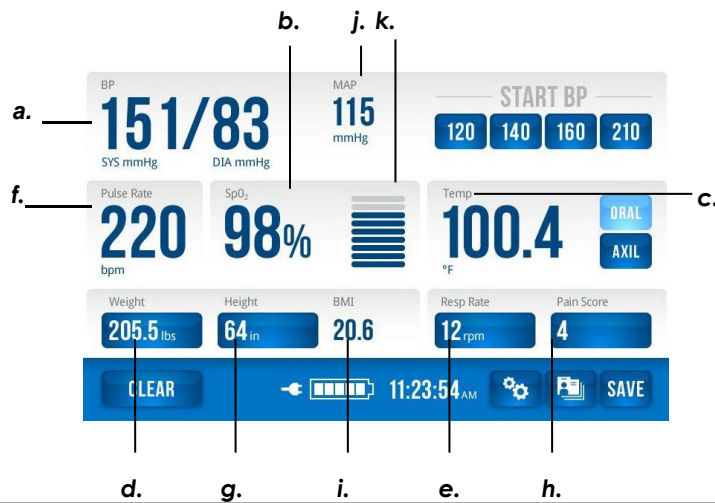

Note

The Respiration Rate and Pain Score parameters can be turned off so that they do not appear in the Main Testing screen. See [Section IX-F, Additional Setting Changes and Options from the More Button](#) in this manual for more details.

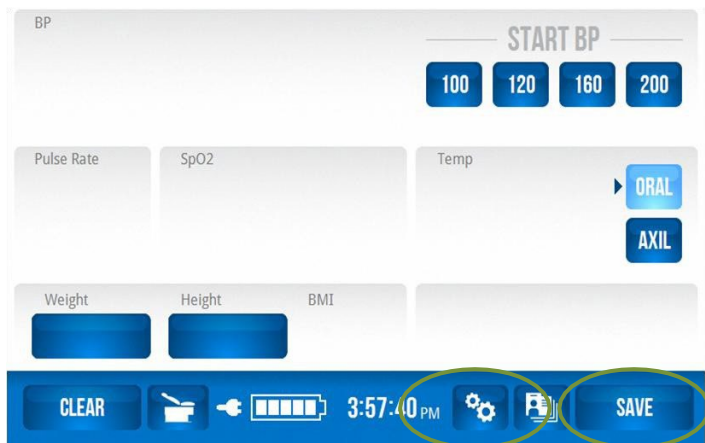

C. Manual Entry of Data

Weight, respiration rate, height and pain score can be manually entered by pressing each corresponding button on the *Main Testing* screen.

A screen with a numerical keyboard will appear where the data can be manually entered. Once the data is entered, press **Save** to save the data, or press **Cancel** to delete the data entered. Once Save has been pressed, the *Main Testing* screen will appear, and the data will be visible.

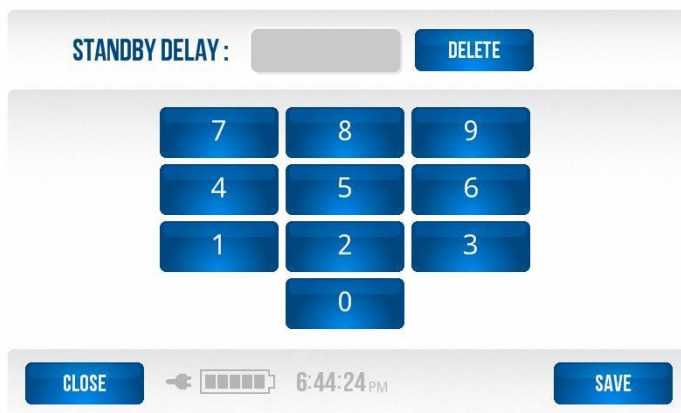

The screenshot shows a mobile application interface for manual data entry. At the top, there is a label "STANDBY DELAY:" followed by a greyed-out input field and a blue "DELETE" button. Below this is a numerical keypad with blue buttons for digits 0-9. At the bottom, there is a blue "CLOSE" button, a battery icon, a digital clock showing "6:44:24 PM", and a blue "SAVE" button.

D. BMI Calculation

BMI is automatically calculated from the height and weight entered. Both data points must be present in order for the BMI to be displayed.

E. Time

On the *Main Testing* screen, a digital clock is displayed in the bottom panel to the right of the **Battery** icon. This clock is updated every second.

F. Table Scale

When the Midmark Digital Vital Signs Device is configured to the Integrated Scale, the **Table Scale** icon will be present to the right of the **Clear** button. See [Section VIII – D Scale Operation](#) for obtaining a weight measurement via the Fairbanks® TeleWeigh™ scale or Integrated Scale. (See [Section XIII Appendix A - Configuring an Midmark Digital Vital Signs Device with the Midmark Integrated Scale](#) for configuring the Midmark Digital Vital Signs Device with the Midmark Exam Chair with Integrated Scale.)



G. Save Button

1. To save vital sign data to memory press the **Save** button.
2. Enter the patient's ID, and press **Save**.



3. Press **Close** to return to the *Main Testing* screen.

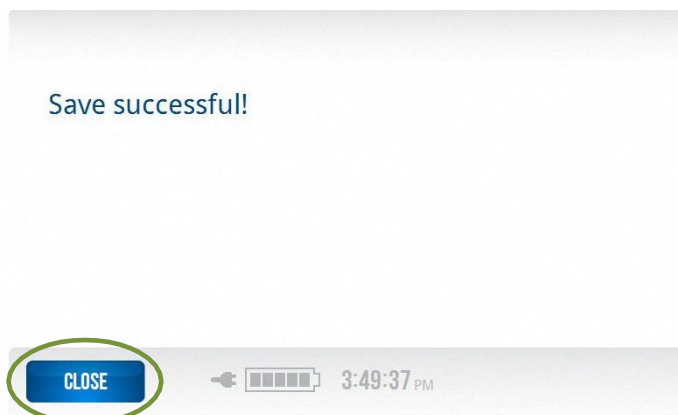

H. Using the Memory Button and Password

1. To access all patient data that is stored in Midmark Digital Vital Signs Device, press the **Memory** button.



This data is password protected, and a password screen will appear when the **Memory** button is pressed. Enter the password, and press **Enter**. The password must be successfully entered in order to view the patient data stored in the memory screen. **The factory set password is 1234.** To set your own password, see [Section IX-C, Memory Setting Button](#) in this manual.

2. Midmark Digital Vital Signs Device holds 100 patient measurements. When the memory is full and another patient test is saved, the first saved test will be deleted in order to save the current test.
3. To view all saved data, use the up and down arrows.
4. To view all saved parameters, press the right arrow.
5. To return *Home*, press the left arrow.
6. Press **Close** to return to the *Main Testing* screen.
7. If an external printer is connected to Midmark Digital Vital Signs Device, select the patient information you want to print, and press the **Print** button. If no patient is selected and the **Print** button is pressed, all patient data visible on the screen will be printed.
8. To delete data for a single patient, touch the patient data on the screen to highlight it. The highlighted entry will be deleted once the **Delete** button is pressed.
9. To delete data for multiple patients, touch and highlight all entries to be deleted. The highlighted entries will be deleted once the **Delete** button is pressed.



After pressing the **Delete** button, a confirmation screen will appear.

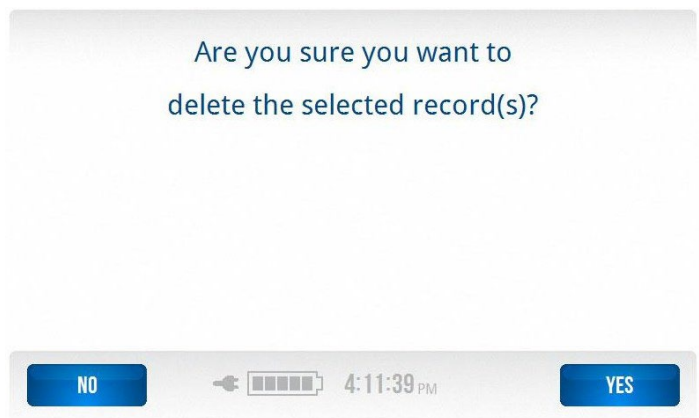

10. Press **YES** or **NO**.
11. To return to the *Main Testing* screen, press the **Close** button at the bottom left corner of the screen.



VIII. Device Operation

A. Blood Pressure

Note

Blood pressure measurements determined with this device are equivalent to those obtained by a trained observer using the cuff/ stethoscope auscultation method, within the limits prescribed by the American National Standard, electronic or automated sphygmomanometers.

Note

There are four pressure setting buttons to choose from; these can be preset to pressure settings of the user's choice. See [Section IX-B, Changing Blood Pressure Inflation Settings](#) of this manual for detailed information on changing pressure settings.

Blood Pressure Cuff Selection

Using the proper size blood pressure cuff is important for accurate blood pressure readings. Midmark recommends using Midmark or UltraCheck® reusable cuffs with the Midmark Digital Vital Signs Device.

- Cuffs that are too small may result in erroneously high blood pressure readings, and cuffs that are too large may result in erroneously low blood pressure readings.
- To verify the proper cuff size for a patient, wrap the cuff around the patient's extremity. The index line (white arrow) should fall within the white range markings on the cuff. If a patient falls between two cuff sizes, always use the larger cuff.



Refer to the following table to identify the size ranges of reusable blood pressure cuffs offered by Midmark. This table lists the cuff part number, name, and size range (based on the circumference of the patient's arm) in centimeters (cm) and inches (in).

Midmark Part #	Name	Size Range (cm)	Size Range (in)
3-009-0068	Infant	8 - 14	3.2 - 5.5
3-009-0070	Child	13 - 20	5.1 - 7.9
3-009-0062	Small Adult	18 - 26	7.1 - 10.2
3-009-0064	Adult	26 - 35	10.2 - 13.8
3-009-0066	Large Adult	32-42	12.6 - 16.5
3-009-0072	Adult Long	29-38	11.4 - 15
3-009-0074	Large Adult Long	35-44	13.8 - 17.3
3-009-0076	Thigh*	42-50	16.5 - 19.7

*Part 3-009-0076 - Thigh is based on the circumference of the patients' thigh.

Note

For accuracy and safety in pediatric blood pressure measurements, the smallest cuff approved for use on infants and small children is the Infant (#3-009-0068). It is important that the child's arm fits within the range markings on the cuff being used.

Proper Application and Positioning of Blood Pressure Cuff

The preferred measurement site for adults and children is the upper arm. Other sites that can be used are the forearm, thigh, or ankle. Do not wrap a cuff over a patient's clothing; inaccuracies can occur. There may also be a marked difference between readings taken from the left arm and right arm.

The cuff should be positioned level with the patient's heart. Measurements made with a cuff placed above heart level will produce lower blood pressure readings, and measurements made with a cuff placed below heart level will produce higher blood pressure readings.

Place the cuff brachial artery marker over or close to the brachial artery. For best results, wrap the cuff snugly so that there is room for no more than two fingers under the cuff.

Initiating a Blood Pressure (BP) Measurement

Start the Midmark Digital Vital Signs Device by pressing the blue On/Off button on the front of the device. From the **Main**

Testing screen:

1. Place the properly sized and positioned blood pressure cuff on the patient.

Note

Keep the patient's arm relaxed and motion free during the measurement. The patient should not talk or move during the BP measurement.

2. To start the blood pressure measurement, **press the appropriate blood pressure inflation rate button** on the *Main Testing* screen.
 - a. Ideally, the initial inflation cuff pressure should be about 30 mmHg above the patient's systolic pressure. Using a higher inflation pressure may cause the patient unnecessary discomfort. Choosing an inflation pressure that is too low may cause the device to re-inflate the cuff in order to obtain a systolic pressure.

³Note

There are four pressure setting buttons to choose from; these can be preset to pressure settings of the user's choice. See [Section IX-B, Changing Blood Pressure Inflation Settings](#) of this manual for detailed information on changing pressure settings.

When a BP measurement is started, the **Stop** button will be highlighted.

- a. To stop a BP measurement at any time, press **Stop**. When the measurement is stopped, the cuff will deflate, and all buttons will be enabled.

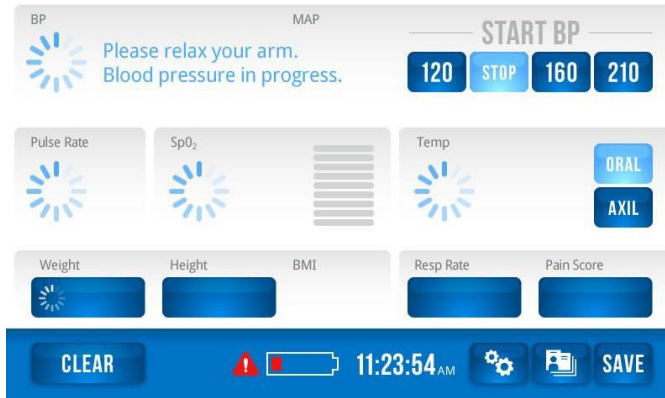

4. While the BP measurement is running, the "in -progress wheel" will appear along with a message that says, "Please relax your arm. Blood pressure in progress."
5. During a BP or any other measurement, the **Clear** button is disabled.
6. When the BP measurement is complete, the systolic and diastolic values appear on the screen.
7. A pulse rate will be displayed when a BP measurement is complete. The pulse rate will appear below "Pulse Rate" on the screen.



8. The **Clear** button will be enabled when the measurement is complete.

B. Temperature

The Alaris® Turbo Temp™ Electronic Thermometer is an electronic thermometer that uses a heat-sensing device known as a thermistor to sense temperature. The thermistor is part of the electrical circuit and is located at the tip of the probe. In normal mode, a final temperature is displayed with an audible beep. To obtain this measurement, the probe tip measures the rate of change in temperature when the thermistor comes in contact with surrounding tissue. A final temperature is calculated based on this rate of change.

Taking an Oral Temperature

1. Verify the **Oral** button in the *Main Testing* screen is light blue. This indicates that the thermometer is in oral mode.



2. For oral temperatures, use the blue oral/axillary probe that is supplied with the Midmark Digital Vital Signs Device.

Note

If the probe needs to be replaced, use only IVAC brand probes available through Midmark.

3. Remove the probe from the probe well, grasping it in the top blue area between the thumb and index finger. Do not press down on the top area where the cord comes out of the top. An audible tone will sound when the probe has been removed from the storage well.
4. Insert the probe in a probe cover, and gently press down on the cover to ensure a secure fit.

Note

Use only IVAC P850A probe covers with the Turbo Temp™ Thermometer. Size, shape, and thermal characteristics of the probe covers can affect the performance of the instrument. Inaccurate readings or retention problems may occur unless IVAC probe covers are used. To avoid cross contamination, use the probe cover only once.

Have the patient open his or her mouth. Place the probe with attached cover in the heat pocket (sublingual pocket) at the back and either side of the mouth (see **Figure 5.1**).

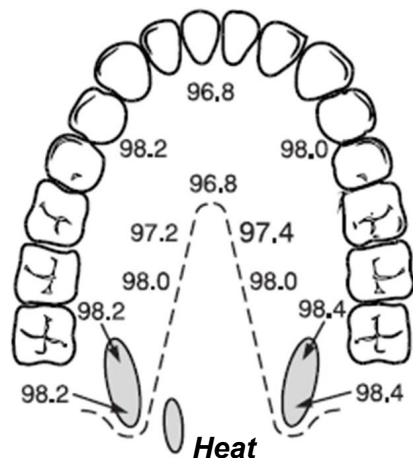

Figure 5.1

Temperatures in the mouth can vary as much as 3°F from the relatively cool hard palate to the warm sublingual area. To take an accurate oral temperature reading, place the thermometer tip in either the right or left posterior pocket (heat pocket) at the base of the tongue.

6. Hold the probe during the entire measurement procedure. Keep the probe in contact with tissue at all times. Do not allow the patient to hold or reposition the probe during the measurement procedure.
7. During temperature measurement, the “in-progress wheel” will appear. The oral measurement in normal mode takes approximately 8 – 10 seconds to complete.



8. An audible tone will sound when the measurement is complete, and the patient's temperature will appear below the **Temp** button on the screen.



Note

If there is a delay of one-minute or longer from the time the probe is taken out of the well until a temperature is taken, the device will not take a temperature. Put the probe back in the storage well and remove it again to reset the thermometer.

Note

Be sure to save the patient's temperature before taking another patient's temperature. The current reading will be cleared when the next temperature reading is taken.

Note

If the probe tip temperature is higher than 94°F (34.4°C) when taken out of the probe storage well, the thermometer will not be able to obtain a measurement and will report a TEMP-313 code. In this case, return the probe to its well and repeat the measurement.

9. To remove the probe cover, hold the probe as you would a syringe, and press the ejection button at the top of the probe (see **Figure 5.2**). Discard the used probe cover according to health care facility protocol.



Figure 5.2

10. Place the probe back in the storage well to reset the thermometer for the next patient.

Taking an Axillary Temperature

In the *Main Testing* screen press the **Axil** button to put the thermometer in axillary mode. If the **Axil** button is light blue, the thermometer is already in axillary mode.

1. Remove the probe from the probe well, grasping it in the top blue area between the thumb and index finger. Do not press down on the top area where the cord comes out of the top. An audible tone will sound when the probe has been removed from the storage well.
2. Insert the probe in a probe cover and gently press down to ensure a secure fit.
3. Lift the patient's arm so that the entire axilla is visible and place the probe in the axilla making sure the tip of the probe is in contact with the skin and positioned close to the axillary artery. Once the probe is securely in place, the patient's arm should be tightly positioned alongside to the body.
4. To ensure continuous tissue contact and minimize patient discomfort, hold the probe in position until the audible tone sounds, indicating that the predictive measurement is complete.
5. Withdraw the probe and eject the probe cover. Discard the used probe cover according to health care facility protocol.
6. Place the probe back in the storage well to reset the thermometer for the next patient.

Note

With an audible tone and visual indication, the device will report a TEMP-313 code under the following conditions:

- Ambient temperature is less than 60.8° F (16°C) or greater than 92.0° F (33.3°C).
- Patient's predicted temperature is below 95.0° F (35°C) or above 106° F (41°C).
- Improper technique or inconsistent tissue contact.
- Over one minute between probe removal from well and tissue contact.

C. Pulse Oximetry Operation (SpO₂)

Applicable only to devices with the SpO₂ feature (device part number 1-100-1610 / kit product number 4-000-0510).

Each SpO₂ capable Midmark Digital Vital Signs Device is shipped with one reusable adult SpO₂ finger clip sensor. Carefully read the sensor directions before using.

2

Note

Refer to [Section XVI Accessories and Supplies](#) for approved SpO₂ sensors.

1. To perform the SpO₂ measurement, insert the patient's finger (preferably the left or right index finger) completely into the sensor. Place the sensor with the LED light positioned on the fingernail.

Note

If patient movement is occurring or the finger size is inappropriate, select a different sensor that is appropriate for the patient.

Note

The thumb should not be used with the finger clip sensor.

Note

If the blood pressure measurement is occurring simultaneously, place the finger clip sensor on the limb opposite the one with the blood pressure cuff.

Note

Avoid dark nail polish or direct sunlight on the probe, as these conditions may result in inaccurate readings.

2. When the SpO₂ sensor is attached to a patient's finger, an audible tone will sound and the "in- progress wheel" will appear.



- When the SpO₂ measurement is complete, an audible tone will sound and the SpO₂ value will appear. The SpO₂ value continues to update as long as the sensor is on the patient's finger.

Note

If the sensor remains on the patient the pulse progress bar on the screen will become active. The SpO₂ value continues to update as long as the sensor is on the patient's finger. After the sensor is removed from the patient, the pulse progress bar will disappear, and the patient's last SpO₂ measurement will be displayed on the screen.



- Should a measurement time exceed 10 minutes for one patient, a 312 error code will be displayed that alerts the user that the SpO₂ has exceeded the 10-minute time limit.

Note

The SpO₂ module is not intended for continuous monitoring of patients.

D. Scale Operation

Fairbanks®

A Fairbanks® TeleWeigh™ Digital Scale, can be used for collecting patient weight. When the scale is connected to Midmark Digital Vital Signs Device the device will automatically detect the scale has been connected and is ready for use. The scale will automatically transfer the weight measurement to the Midmark Digital Vital Signs Device.

For complete information regarding the Fairbanks® TeleWeigh™ Digital Scale, consult the user information provided with the scale or go to www.fairbanks.com.

Fairbanks® TeleWeigh™ Digital Scale	
Category	Specifications
Measurement Range	0 to 500 lbs
Resolution	0.5 lbs
Zeroing	Automatic
Power	12 VDC (from Midmark Digital Vital Signs Device® device)

Midmark Integrated Scale

A Midmark Exam Chair with Integrated Scale can be used for collecting patient weight. When configured with the Midmark Digital Vital Signs Device the Integrated Scale can take the patient's weight measurement while the patient is seated on the exam table.

For complete information regarding the operation of the Midmark Exam Chair with Integrated Scale, consult the Integrated Scale operation manual at www.midmark.com.

Midmark Integrated Scale

Category	Specifications
Measurement Range	30 to 600 lbs
Resolution	0.2 lbs
Zeroing	Button Press
Power	115 ± 10% VAC, 60 Hz, 15A (Midmark Barrier-Free® Examination Table)

Note

In order to connect the Midmark Digital Vital Signs Device to the Integrated Scale one of the following cables will be required:

- Midmark Digital Vital Signs Device Serial Cable, 6 foot length, coiled (9A478001)
- Midmark Digital Vital Signs Device Serial Cable, 15 foot length, straight (9A478002)

Contact your local sales representative for ordering information.

See [Section XIII - Appendix A - Configuring an Midmark Digital Vital Signs Device with the Midmark Integrated Scale](#) for complete instructions on how to configure the Midmark Digital Vital Signs Device with the Integrated Scale.

When the Midmark Digital Vital Signs Device is configured to the Integrated Scale, the Table Scale button will appear to the



right of the **Clear** button on the Midmark Digital Vital Signs Device *Main Testing* screen.

From the main testing screen press either the **Weight** button or the **Table Scale** button. The *Midmark Exam Chair* screen will appear.

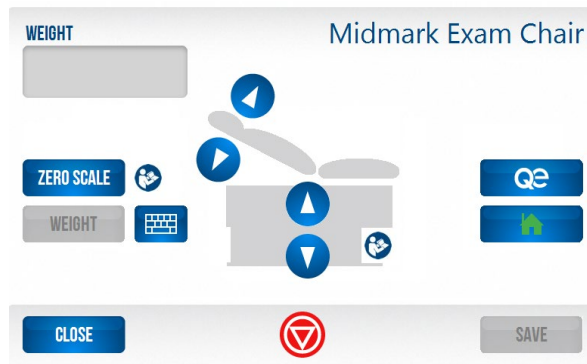

Note

The **Save** button is grayed out since there is no weight recorded yet. Even if a weight was previously recorded, that record will not be transferred to this screen.

Note

The **Weight** button **will be grayed out if the table has not been zeroed.**

- The arrow buttons control the table movement.

- The **Qe** (Quick exam) button sends the table to a pre-configured height (the height can be configured using the hand control).
- The **Home** button sends the table to a default height.
- The **STOP** button stops (red button circumscribing a white triangle) the movement of the table.

When the **Zero Scale** button is pressed, the button will display the “in-progress wheel” until the scale is zeroed.

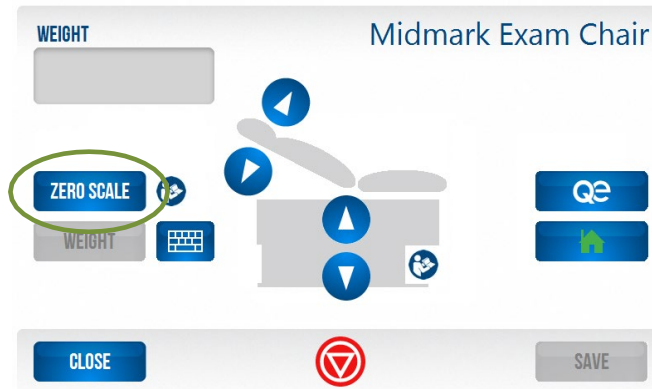

Once the scale is zeroed, a “Scale Ready” message will appear. (The Integrated Scale can be zeroed multiple times before acquiring the weight). Once the scale is zeroed, the **Weight** button becomes active indicating the option to take a weight measurement is available.

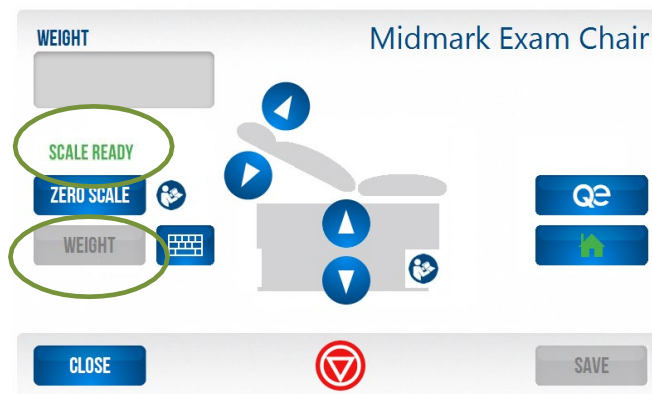

When the **Weight** button is pressed, the table will move to ensure that the patient's feet are off the floor. The "in-progress wheel" will appear during the weight acquisition.

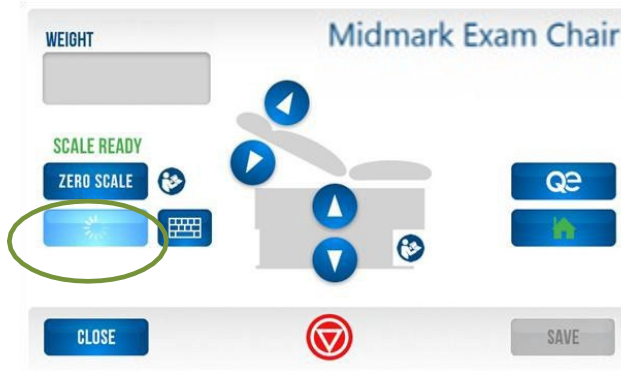

The weight data will appear on the screen once the weighing process is complete.

- Units are displayed based on the user settings, and two decimal points are shown for both kilograms and pounds.
- After weight acquisition, the **Save** button becomes active indicating the option to save the weight is available.



If the Integrated Scale returns a weight that is out of range (less than 30 lbs or more than 600 lbs), the screen will display a red flashing message that says, "Out of Range," and the weight will be displayed in red. The option to save the weight will NOT be available.

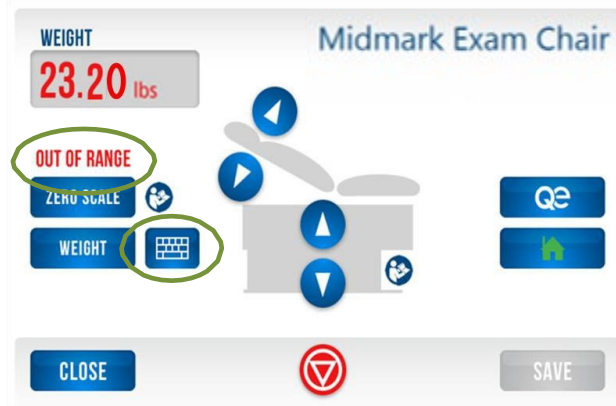

If the weight is out of range or unstable, enter the weight manually using the keypad on the display.

If the **Close** button is pressed after acquiring the weight, a warning message will appear that says, “Do you want to save the weight data?” Press **Yes** or **No** to close the message and return to the *Main Testing* screen.

E. Printer Operation

The Midmark Digital Vital Signs Device printer can be used to print all patient vitals data collected by the Midmark Digital Vital Signs Device. Midmark Digital Vital Signs Device will automatically transfer patient data to the printer when the **Print** button is pressed.

1. To print patient data,
 - a. Press the **Save** button.
 - b. Enter the patient ID.
 - c. Press **Save**.
 - d. Press **Yes** to save the patient data.
 - e. The memory screen will appear; press the **Print** button.
2. The Midmark Digital Vital Signs Device can be set to automatically print the patient data when the **Save** button is pressed. For information on how change this option, see [Section IX-F, Additional Setting Changes and Options from the More Button](#).

F. Manual Entry of Information

Weight, respiration rate, height and pain score can be entered manually by pressing each corresponding button on the *Main Testing* screen. The following table shows the allowable range for each.

Information	Allowable Range
Pain Score	0 – 10, and Wong Baker Pain Score
Respiration Rate	4 – 120 RPM
Height	10 – 100 inches (25.4 – 254 cm)
Weight	1 – 1,000 lbs (1 – 500 kg)

Note

If a manual entry falls outside the range, an error message will appear prompting for entry of a score within the range.

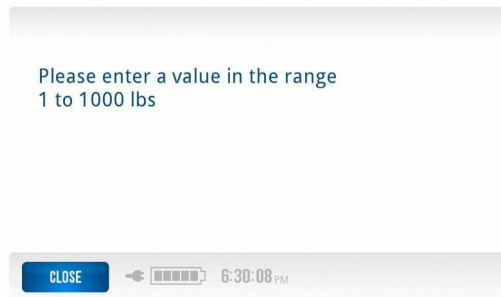

G. Pain Scale

When the button underneath the **Pain Score** label is selected, the following screen will appear.

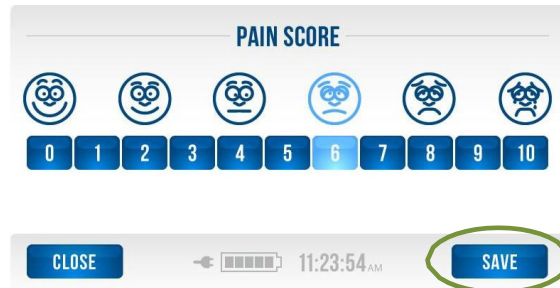

If a pain score has already been selected, it will be highlighted. Otherwise, none of the pain scores will be highlighted.

1. Select the appropriate pain score by pressing the corresponding number on the screen.
2. Press **Save** to transfer the new pain score to the patient record and return to the *Main Testing* screen.

3. Press **Close** to disregard any changes and return to the *Main Testing* screen.

Note

Pain Score will only transfer to the patient record if the Save button is pressed. If a pain score is selected but the Close button is pressed the changes will be canceled and will not be transferred to the patient record.

IX. Additional Functionality and Settings

A. Settings Button and Password

In the *Main Testing* screen, press the **Settings**  button to access additional functions and settings. A password screen will appear. These additional screens are password protected to keep any unintended changes from taking place. **The factory password is set at 986 and cannot be changed.**

Enter the password **986**, and press **OK**.



From this screen, select one of the following options:

- BP Settings
- Memory Settings
- Monitor settings.

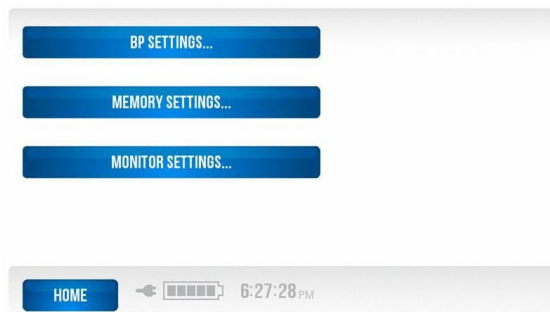

To return to the *Main Testing* screen at any time, press the Home button.

B. Changing Blood Pressure Inflation Settings

There are pre-set, default blood pressure inflation settings for **Low**, **Medium**, **Medium High**, and **High** pressure settings for the device. These values can be changed to accommodate specific preset blood pressure inflation settings.

BP Settings	Default (mmHg)
Low	100
Medium	120
Medium-High	160
High	200

To change a blood pressure inflation setting from a default value:

1. Press the **BP Settings** button.



2. Press the appropriate button for the inflation setting to be changed.



3. A numeric keyboard will appear. To clear the current setting, press the **Delete** button on the screen.

4. Enter the desired pressure preset setting by pressing the numbers on the screen.

5. Press the **Save** button to save the setting and return to the previous screen. To return to the main testing screen, press **Close**.



Note

Each BP setting has a maximum allowable range.

BP Settings	Default (mmHg)	Allowable Range (mmHg)
Low	100	80-140
Medium	120	110-180
Medium-High	160	130-210
High	200	160-270

If an entry falls outside the range or overlaps an adjacent BP setting, an error message will appear prompting for entry of a value within range. Blood pressure ranges displayed in an error message may vary, depending on the values of the adjacent BP settings.



Example of error message for an out of range value entered for the Low BP setting if the Medium BP setting is at the 120 mmHg default value.

C. Memory Setting Button

Press the **Memory Settings** button to change the password for the *Memory* screen, for viewing saved patient data and clear saved data from the device.



The password to enter the *Memory* screen to view saved patient data is factory set. **The factory set password is 1234.**

To reset the *Memory* screen user password:

1. Press the Memory password button.

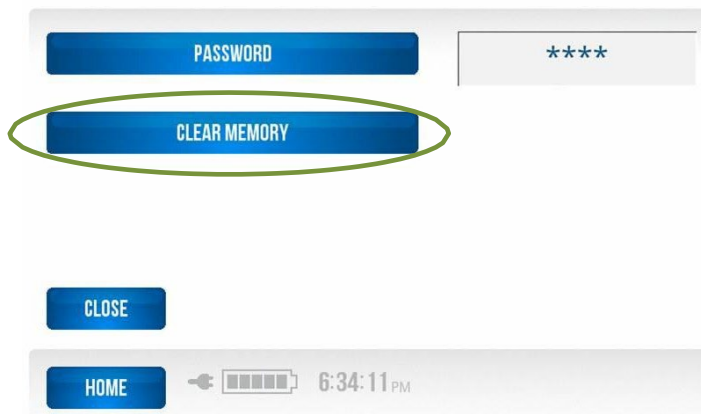

2. Use the left or right arrow keys to move the cursor one space at a time. Use the **Delete** button to remove the current password.

3. Enter new password, and press **Save**.



4. Once the data is saved, the password will be represented by an asterisk for each character.
5. Press **Close** to return to the previous screen.
6. Press **Home** to return to the *Main Testing* screen.

To clear all saved data in the *Memory Screen*:

Note

This will clear all patient data saved in the device memory.

1. Press the Clear Memory button. This will clear all patient data saved in the device memory.

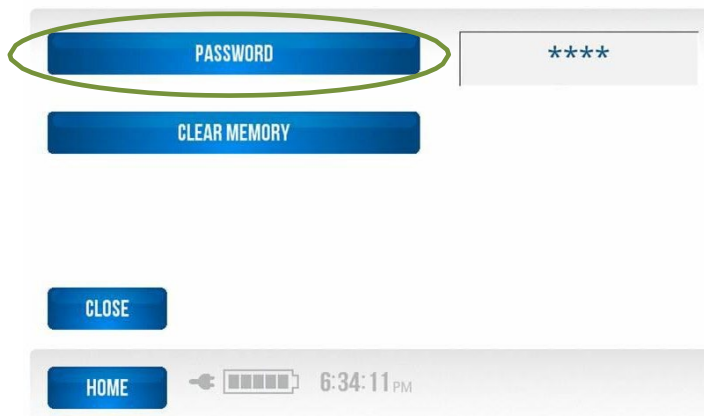

2. The system will display the following message and prompt for a confirmation.
 - a. Press **YES** or **NO**.

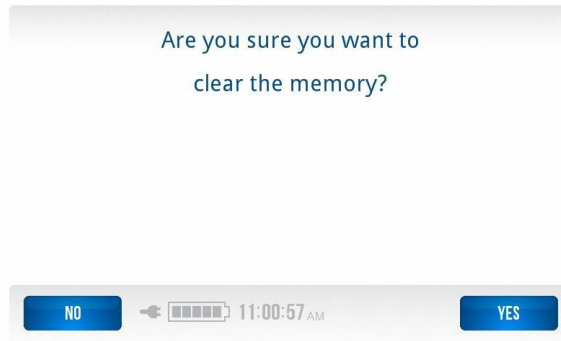

D. Monitor Settings Button

To access this screen quickly:

1. Press the **SETTINGS** icon on the Main Testing screen.
2. Enter the default password of **986** on the touchscreen.
3. Press **OK**.

Press the **Monitor Settings** button to change the following settings for the Midmark Digital Vital Signs Device.

- Volume
- Brightness
- Time

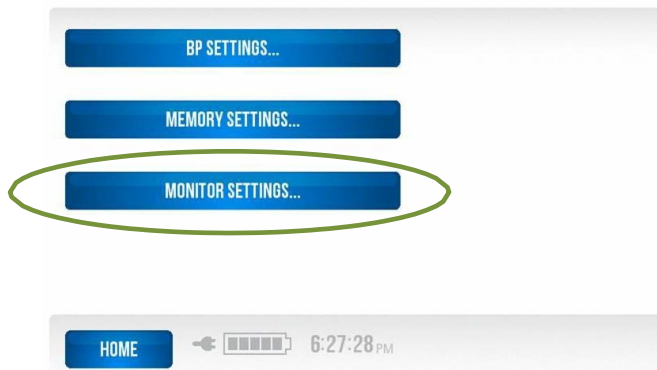

Volume

1. Press the Volume button to change the volume level.



2. There are five volume levels to choose from: Loudest, Louder, Normal, Softer, and Softest.
3. Press OK to save the chosen volume level and return to the previous screen.

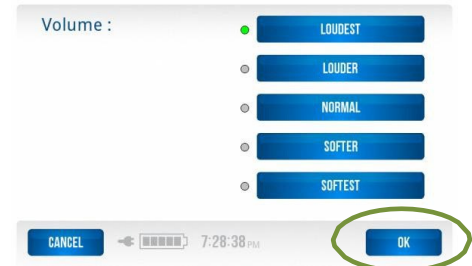

Brightness

1. Press the Brightness button to adjust the brightness on the touch screen display.



2. There are five brightness options to pick from: Brightest, Brighter, Dimmer, Dimmest, Normal.
3. Press OK to save the chosen brightness level and return to the previous screen.

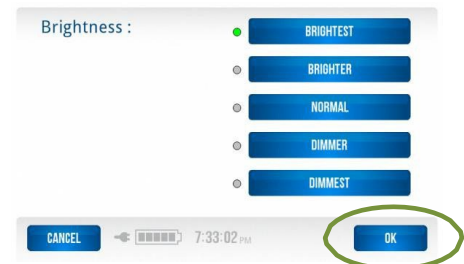

Date and Time

1. To change the time for the Midmark Digital Vital Signs Device, press the Set Date and Time button.



2. Use the up and down arrows for changes.
3. Press **OK** to save changes and return to the previous screen.
4. Press **Close** to return to the previous screen.
5. Press **Home** to return to the *Main Testing* screen.

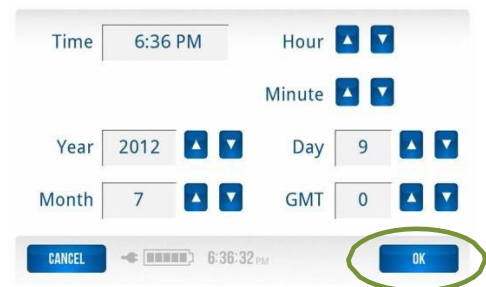

E. Setting Changes via the More button

To access this screen quickly:

1. Press the **SETTINGS** icon on the main testing screen.
2. Enter the default password of **986** on the touchscreen.
3. Press **OK**.
4. Press **MONITOR SETTINGS**.

The following settings can be modified when pressing the **More** button from “Volume, Brightness, Set Date and Time” screen:

- Temp Measurement
- Weight Measurement
- Height Measurement
- Table – to Configure Midmark Digital Vital Signs Device with Integrated Scale (applies only when the Midmark Digital Vital Signs Device is used with the Midmark Exam Chair and Integrated Scale) See [Section XIII - Appendix A - Configuring an Midmark Digital Vital Signs Device with the Midmark Integrated Scale](#) for detailed instructions to configure the Midmark Digital Vital Signs Device with the Integrated Scale.

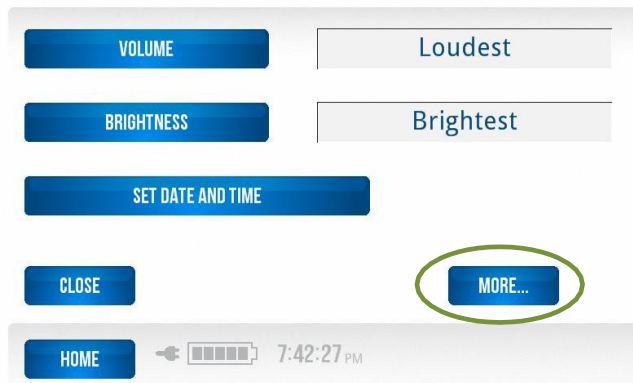

Set Temp Measurement

1. Press the **Temp** button to select °C or °F for the temperature measurement.

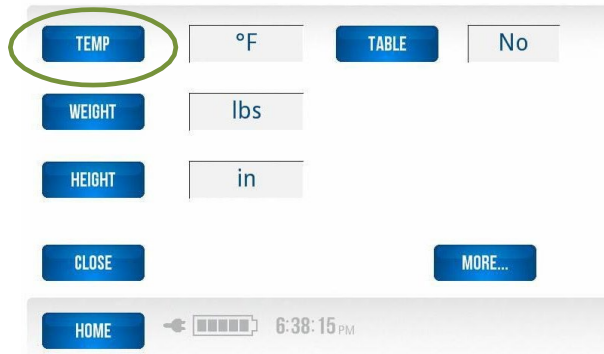

2. Select the **°F** or **°C** button.

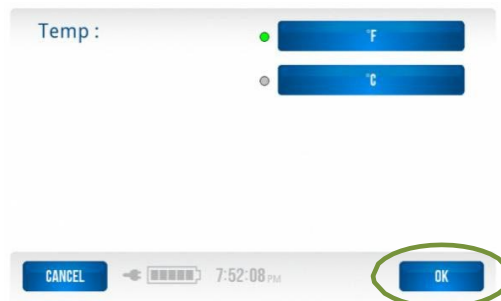

3. Press **OK** to save the setting and return to the previous screen.

Set Weight Measurement

1. Press the **Weight** button to set measurement units to pounds (lbs) or kilograms (kg).



2. Select the **lbs** or **kg** button.
3. Press **OK** to save the setting and return to the previous screen.

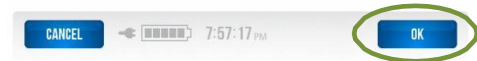

Set Height Measurement

1. Press the **Height** button to select height being measured in inches or centimeters (cm).



2. Select the **IN** (inches) or **CM** (centimeters) button.
3. Press **OK** to save the setting and return to the previous screen.

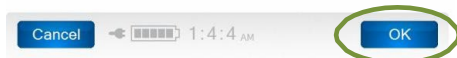

Table - Configure Midmark Digital Vital Signs Device with Integrated Scale

1. Press the **TABLE** button.



2. Select **YES** for the table connection.
3. Press **OK** to save the setting and return to the previous screen.



F. Additional Setting Changes and Options from the More Button

Additional settings and options can be modified when pressing the **More** button from the following screen:

- Date Format
- Time Format
- Standby Delay
- Show Respiratory Rate
- Show Pain Score
- Show MAP
- Print on Save
- Find Midmark Digital Vital Signs Device® Software Version

Number To access this screen from the main screen:

1. Press the **Settings Button** .
2. Enter the Password **986**.
3. Press the **Monitor Settings** button.

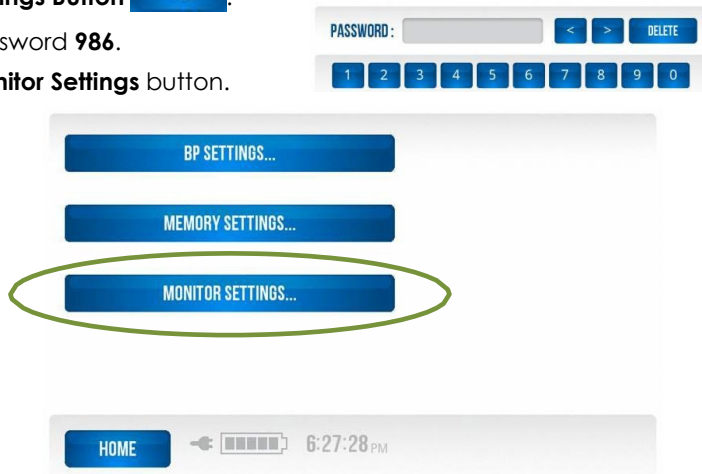

4. Press the **More** button.

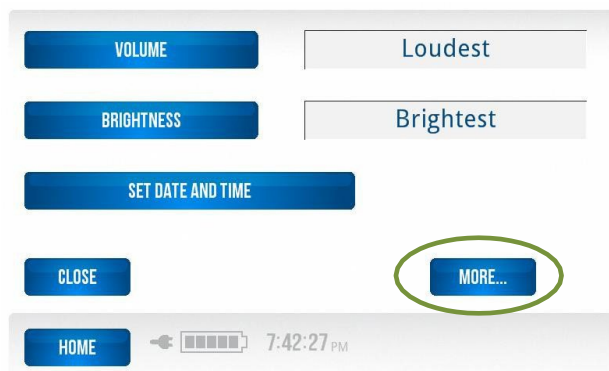

5. Press the **More** button from this screen to access the remaining settings.



Set Date Format

1. Press the **Date Format** button to change the date format.

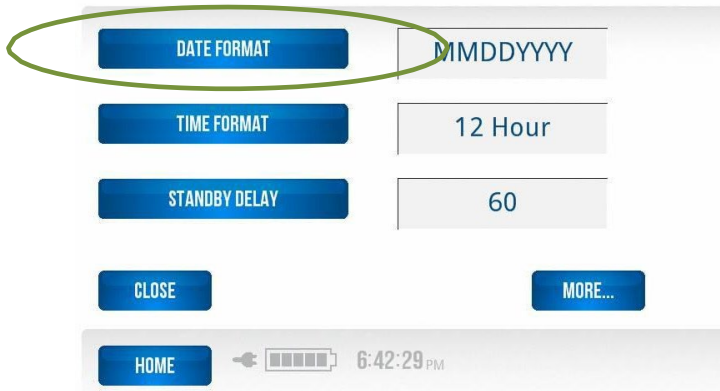

2. Select one of three formats (MMDDYYYY, DDMMYYYY, and YYYYMMDD).
3. Press **OK** to save and return to the previous screen.



Set Time Format

1. Press on the **Time Format** button to change the time format.



2. Select the 12- or 24-hour format.
3. Press **OK** to save and return to the previous screen.

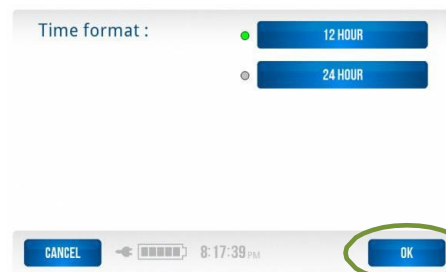

Set Standby Delay

1. Press the **Standby Delay** button to select how long the device will wait before going into standby mode.



2. Choose from 1 to 1,440 minutes.
3. When the **Standby Delay** button is pressed, a numerical keyboard will appear.
4. To clear the current setting, press the **Delete** key on the screen.
5. Enter the number of minutes wanted for the device to wait before entering standby.
6. Press **OK** to save and return to the previous screen.



Set Show Resp Rate

1. Press the **More** button from the following screen.

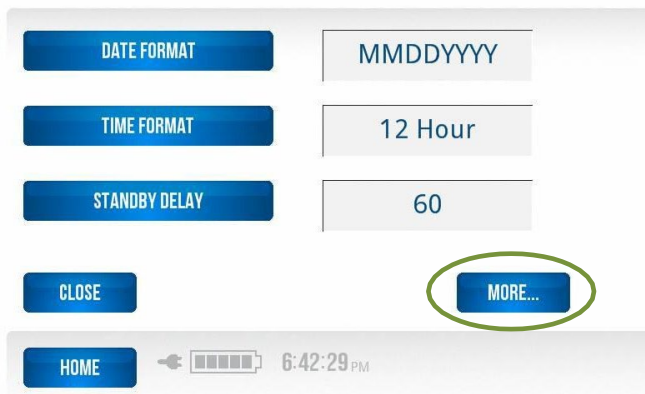

2. Press the **Show Resp Rate** button to select whether or not the respiration rate will appear in the *Main Testing* screen.

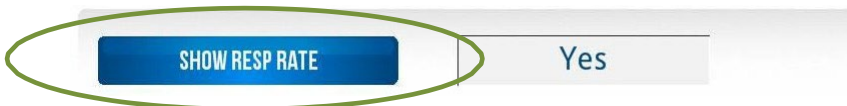

3. Select **Yes** or **No**.
4. Press **OK** to save the selection and return to the previous screen.



Set Show Pain Score

1. Press the **Show Pain Score** button to select whether or not the pain score will appear in the *Main Testing* screen.



2. Select **Yes** or **No**.
3. Press **OK** to save the selection and return to the previous screen.



Set Show MAP

1. Press the **Show MAP** button to turn on the Mean Arterial Pressure. The device comes set with the MAP off. If this function is turned on the MAP will now be displayed below the Blood Pressure reading in the main testing screen when a Blood Pressure is completed.



2. Select **Yes** or **No**.
3. Press **OK** to save the selection and return to the previous screen.

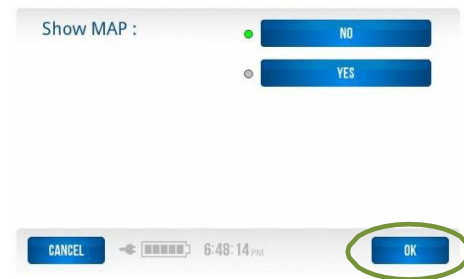

Set Print on Save

1. Press the **More** button from the following screen.



2. Press the **Print on Save** button to select whether or not the patient test data is automatically printed when you press **Save**. (This function is turned off in the default settings.)

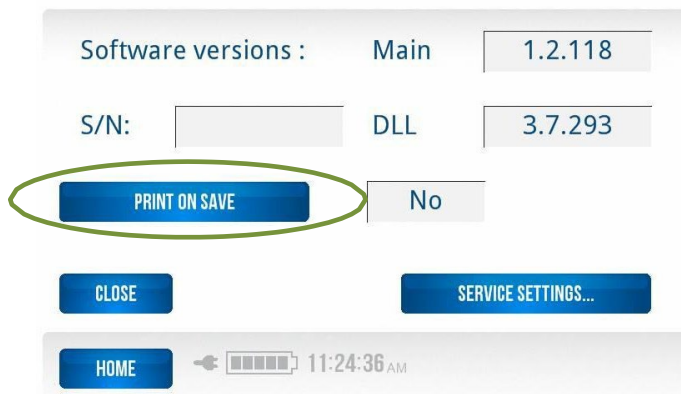

3. Select **Yes** or **No**.
4. Press **OK** to save the selection and return to the previous screen.



Find Midmark Digital Vital Signs Device Software Version Number

1. Press the **More** button from the following screen.

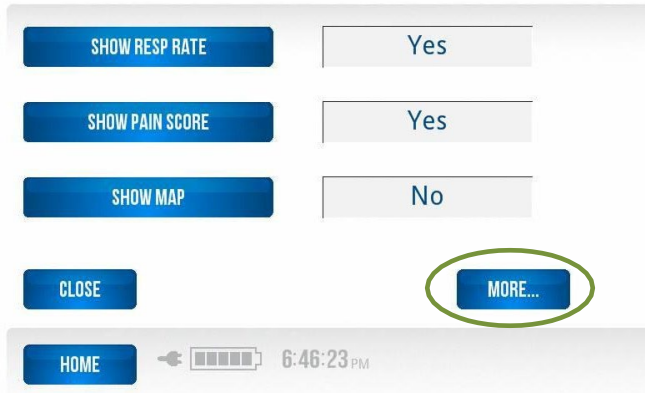

2. The software version number will be displayed at the top of the screen. **When contacting Technical Service, please have this version number available.**

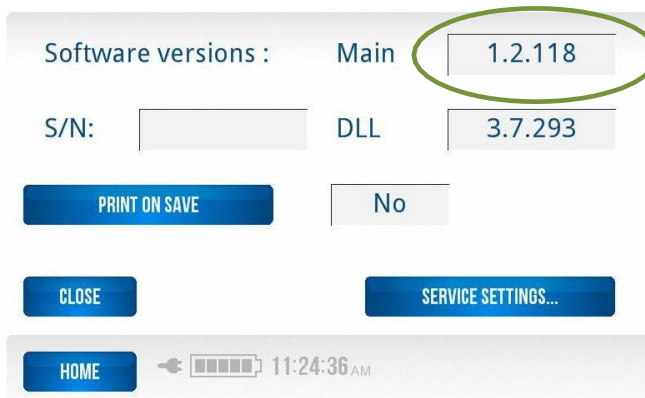

3. **S/N** stands for "serial number." The serial number can be found here or on the bottom label on the device.

S/N: [] DLL 3.7.292

4. **Service Settings** are intended for manufacturer use only. For more information contact [Midmark Technical Service](#).

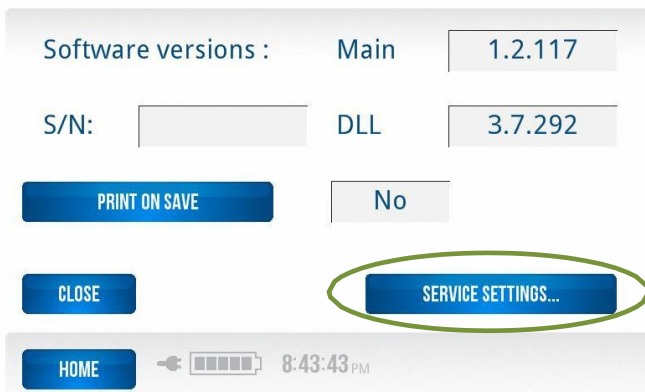

X. Error Codes and Corrective Actions

The following table contains corrective actions for issues that may be encountered while operating Midmark Digital Vital Signs Device. If an issue persists after completing the recommended actions provided below, contact [Midmark Technical Service](#). All error codes will appear in separate boxes similar to the image below.

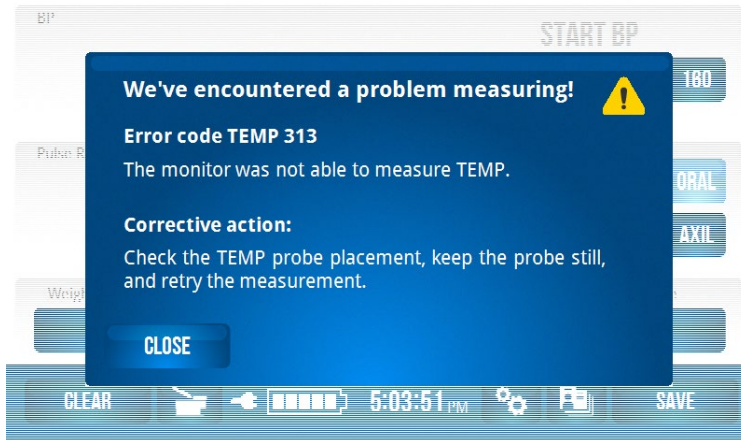

Code	Meaning	Displayed Description	Corrective action
NIBP 305	Artifact	The monitor was not able to measure blood pressure.	Request that the patient remain still. Retry the measurement.
NIBP 306	Hardware failure	The monitor cannot measure blood pressure.	Power cycle the monitor. (Power the unit off for a short time, and then power the unit on again.) If problem persists, contact Midmark Technical Service .
NIBP 309	Overpressure	The cuff pressure was too high.	Request that the patient remain still. Retry the measurement.
NIBP 310	Blocked line	The BP hose is constricted.	Straighten out the hose. Retry the measurement.
NIBP 311	Open line	The BP cuff is not inflating.	Check to make sure the NIBP hose and cuff are attached to the monitor. If problem persists, contact Midmark Technical Service .
NIBP 312	Measurement timeout	The blood pressure measurement was taking too long to complete.	Request that the patient remain still. Retry the measurement.
NIBP 313	Cannot measure	The monitor was not able to measure blood pressure.	Request that the patient remain still. Retry the measurement.

Code	Meaning	Displayed Description	Corrective action
NIBP 314	Weak signal	The monitor was not able to measure blood pressure.	Check to see that the cuff is reasonably tight or consider using a smaller cuff. Request that the patient remain still. Retry the measurement.
SpO ₂ 302	Unplugged	The SpO ₂ cable is disconnected from the monitor.	Connect the SpO ₂ cable to the monitor. Retry the measurement.
SpO ₂ 305	Artifact	The monitor was not able to measure SpO ₂ .	Request that the patient remain still. Retry the measurement.
SpO ₂ 306	Hardware failure	The monitor cannot measure SpO ₂ .	Power cycle the monitor. If problem persists, contact Midmark Technical Service .
SpO ₂ 312	Time Out	The monitor was not able to obtain or finish a SpO ₂ measurement in time.	Check the SpO ₂ sensor placement. Check to see if the patient has cold hands. If patient is moving request they remain still. Retry the measurement.
SpO ₂ 314	Weak signal	The monitor was not able to measure SpO ₂ .	Check the SpO ₂ sensor placement. Check to see if the patient has cold hands. Retry the measurement.
SpO ₂ 315	Probe fault	There is a problem with the SpO ₂ sensor.	Replace the SpO ₂ sensor. If problem persists, contact Midmark Technical Service .
SpO ₂ 316	Check sensor	The SpO ₂ sensor is misaligned or came off the patient.	Check the SpO ₂ sensor placement. Retry the measurement.
TEMP 302	Unplugged	The TEMP cable is disconnected from the monitor.	Connect the TEMP cable to the monitor and retry the measurement.
TEMP 304	Temp too high	The monitor was not able to measure TEMP.	Check the TEMP probe placement. Keep the probe still. Retry the measurement.
TEMP 306	Hardware failure	The monitor cannot measure TEMP.	Power cycle the monitor. If problem persists, contact Midmark Technical Service .
TEMP 313	Cannot measure	The monitor was not able to measure TEMP.	Check the TEMP probe placement. Keep the probe still. Retry the measurement.
TEMP 315	Probe fault	There is a problem with the TEMP probe.	Replace the TEMP sensor. If problem persists, contact Midmark Technical Service .
TEMP 330	Temp too low	The monitor was not able to measure TEMP.	Check the TEMP probe placement. Keep the probe still. Retry the measurement.
BAT 325	Battery low	Battery low	Connect monitor to wall outlet to recharge battery.
REC 327	Recorder door open	The printer door is open.	Close printer door.
REC 328	Recorder paper out	The printer is out of paper.	Replace paper in printer.
REC 329	Recorder fault	There is a problem with the printer.	Replace the printer. If problem persists, contact Midmark Technical Service .
Monitor			
MON 332	Monitor fault	The monitor detected an internal problem.	Power cycle the monitor. If problem persists, contact Midmark Technical Service .

Trouble Symptom	Possible Causes	Things to Try
The Midmark Digital Vital Signs Device is plugged in, but it does not start up.	No power to outlet.	Verify that the power outlet is working. Verify that the green power LED on the Midmark Digital Vital Signs Device front panel is illuminated.
	The Midmark Digital Vital Signs Device Power Supply is not working.	Verify that the green charging LED on the Midmark Digital Vital Signs Device front panel is illuminated. If possible, try using a different Midmark Digital Vital Signs Device Power Supply.
	The Midmark Digital Vital Signs Device is powered off.	Set the power switch to the On position.
	Internal system error.	Power cycle the Midmark Digital Vital Signs Device. If the condition persists, stop using the device. Contact Midmark Technical Service .
	Patient is moving.	Ask patient to remain still.
The Midmark Digital Vital Signs Device touch screen is not working.	Touch screen failure	Power cycle the Midmark Digital Vital Signs Device. If the condition persists, stop using the Midmark Digital Vital Signs Device. Contact Midmark Technical Service .
The Midmark Digital Vital Signs Device display is not working.	Display failure	Power cycle the Midmark Digital Vital Signs Device. If the condition persists, stop using the Midmark Digital Vital Signs Device. Contact Midmark Technical Service .
The Midmark Digital Vital Signs Device speaker is not working.	Speaker failure	Power cycle the Midmark Digital Vital Signs Device. If the condition persists, stop using the Midmark Digital Vital Signs Device. Contact Midmark Technical Service .
The Midmark Digital Vital Signs Device is not working and displays an error message.	Operating system failure	Power cycle the Midmark Digital Vital Signs Device. If the condition persists, stop using the Midmark Digital Vital Signs Device. Contact Midmark Technical Service .

XI. Cleaning of Midmark Digital Vital Signs Device and Accessories

The following table provides instructions about for cleaning the Midmark Digital Vital Signs Device and its accessories. The Midmark Digital Vital Signs Device should be cleaned monthly or as warranted. Before cleaning, refer to the cautions listed below.

Part	Recommended Cleaning Method
Midmark Digital Vital Signs Device Temperature Probe Cable SpO ₂ Cable NIBP Cuff NIBP Hose Power Supply Power Cord	<p>Materials</p> <ul style="list-style-type: none"> • Enzymatic detergent such as ENZOL® (US) or CIDEZYME® (outside the US) • Distilled water • Disinfectant solution (such as CIDEX® OPA, or a 10% solution of household bleach (5.25% sodium hypochlorite) in distilled water) • Soft cloths and/or soft-bristled brushes • Protective gloves and <p>eyewear Procedure</p> <ol style="list-style-type: none"> 1. Disconnect the unit from the wall outlet. 2. Put on gloves and protective eyewear. 3. Prepare the enzymatic detergent, or disinfectant solution, according to the manufacturer's instructions and in separate containers. 4. Apply detergent to product using a soft cloth. If material is dried on, allow to sit for one minute. 5. Wipe smooth surfaces with the cloth. 6. Use a soft-bristle brush on visibly soiled areas and irregular surfaces. 7. Remove detergent from product using cloth dampened in distilled water. 8. Repeat as necessary. 9. Apply disinfectant solution on affected area using a soft cloth. Allow product to sit for five minutes. 10. Wipe away excess solution, and clean product again with cloth dampened in distilled water. 11. Allow two hours for drying.
SpO ₂ Sensor	<p>Materials</p> <p>70% isopropyl alcohol</p> <p>pad Procedure</p> <ol style="list-style-type: none"> 1. Remove sensor from patient and disconnect sensor cable from the device. Wipe off with alcohol pad. Allow sensor to dry before placing it on a patient.
Temperature Probe Covers	Temperature probe covers are one-time use only.

**Caution**

Always disconnect the Midmark Digital Vital Signs Device from AC power before cleaning.

**Caution**

Electronic devices can be damaged by exposure to liquids. Do not use or store the Midmark Digital Vital Signs Device near any type of liquids.

**Caution**

Do not use harsh chemicals for cleaning, especially disinfectants that contain phenol, as they can spot plastics. Do not steam-autoclave, gas-sterilize, or irradiate the unit; subject the unit to intense vacuum; or immerse the unit in water or cleaning solution. Keep cleaning liquids out of the unit and connectors. If any liquid gets inside the unit, allow it to dry in warm air for two hours, and then check to make sure all monitoring functions are working properly.

**Caution**

Take particular care when cleaning the blood pressure cuff, blood pressure hose, and blood pressure connector on the Midmark Digital Vital Signs Device to prevent fluid from entering the connectors. Fluid in the blood pressure airway may affect blood pressure determination accuracy and damage the monitor.

**Caution**

Accessories that fall on the floor should be inspected for contamination and proper functionality. In case of contamination, follow the cleaning procedure detailed above.

**Caution**

The user accepts responsibility for any deviations from the recommended method of cleaning and disinfection.

XII. Maintenance, Storage and Battery Replacement

A. Maintenance

The following table shows the recommended maintenance procedures for the Midmark Digital Vital Signs Device and its accessories. Midmark Digital Vital Signs Device requires periodic calibration checks. It is a good idea to check that the device is in good working order, as described in the table. Calibration checks should be done every 12 months and can be performed by qualified service personnel.

Midmark Digital Vital Signs Device® Function	Procedure
Mechanical Integrity	Check for cracks, abrasive edges, and other signs of damage.
Touch screen	Verify that screen is responsive to touch
Power Supply LED	Verify that the green power LED is illuminated on the Midmark Digital Vital Signs Device Power Supply when power supply is plugged into AC power.
Power LED	Verify that the green power LED is illuminated on the Midmark Digital Vital Signs Device when plugged into AC power.
On/Off LED	Verify that the green On/Off LED is illuminated on the back of the Midmark Digital Vital Signs Device when the unit is on.
Speaker	Power-cycle the Midmark Digital Vital Signs Device and verify that the power-up speaker test tones are generated.
SpO ₂	Apply the pulse oximeter probe to your finger. Verify that the reported pulse rate matches your pulse rate as measured on your wrist and that the SpO ₂ value seems reasonable (above 95% for a healthy nonsmoker).
NIBP	Apply an appropriately sized blood pressure cuff to your arm. Measure your blood pressure and verify that the reported blood pressure is reasonably close to your typical blood pressure.
Temperature	None (self-checking)

If one of the checks results in a functional failure, please contact [Midmark Technical Service](#). If a Midmark Digital Vital Signs Device needs to be returned for repair or service, a return authorization number must first be obtained from Technical Service.

B. Storage

Storage Temperature	-4 to 140°F (-20 to 60° C)
Storage Humidity	15% to 95% non-condensing
Storage Altitude	0 to 40,000 feet



Caution

The Midmark Digital Vital Signs Device may not conform to all of its performance specifications if stored outside these environmental specifications or used outside of the environmental specifications in [Section II-D, System Specifications](#) of this manual.

C. Battery Replacement



Caution

Only use the lithium ion battery from Midmark. Using the incorrect battery will cause damage to the Midmark Digital Vital Signs Device and void the warranty.

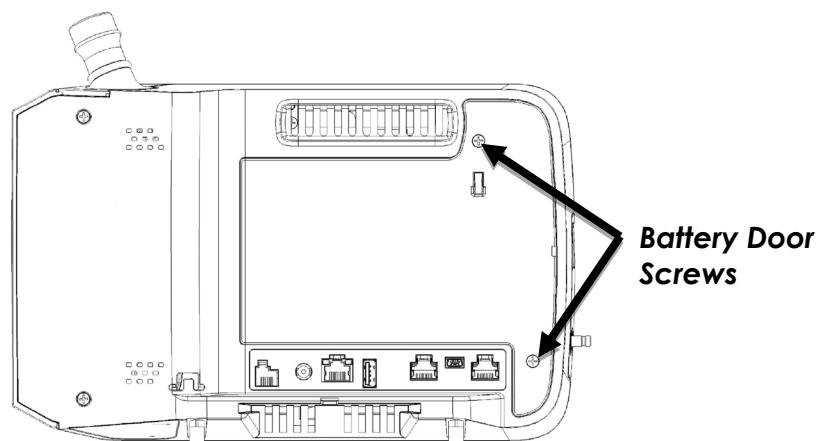

Note

A Phillips head screw driver will be needed to complete the following steps.

1. Turn the device over to view the back of the device. There are two screws in the battery door. The battery door is located on the right, back side of the device. Remove the two screws and remove the battery door.
2. Hold a hand over the battery and tip the device so that the battery falls out of the device and into the hand.
3. Replace the battery with a new one, being careful to place the new battery in the device the same way the old battery came out of the device.
4. Replace the battery door and tighten the two screws. Do not over tighten the screws.
5. Connect the AC power transformer to the Midmark Digital Vital Signs Device and allow the new battery to charge for approximately four hours.

Note

The battery is a lithium ion battery and must be recycled or disposed of properly according to national or local regulations.

XIII. Appendix A - Configuring a Midmark Digital Vital Signs Device with the Midmark Integrated Scale

Note

In order to connect the Midmark Digital Vital Signs Device to the Integrated Scale one of the following cables will be required:

- Midmark Digital Vital Signs Device Serial Cable, 6 foot length, coiled (9A478001) or
- Midmark Digital Vital Signs Device Serial Cable, 15 foot length, straight (9A478002)

Contact your local sales representative for ordering information.

Follow the installations instructions that accompany Serial Cable.

1. With the Serial Cable in place, power-on the Midmark Digital Vital Signs Device.

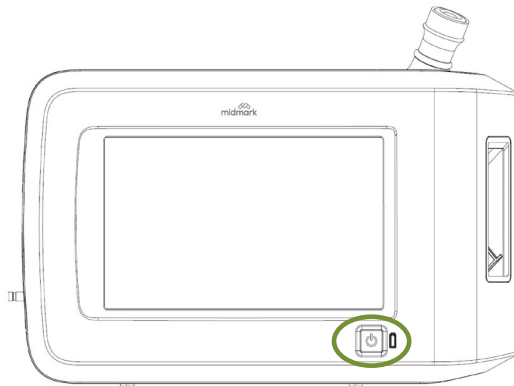

2. From the Main Testing Screen, press the **Settings** button.



3. Enter the default password **986** and press **OK**.



4. Press the **Monitor Settings** button.

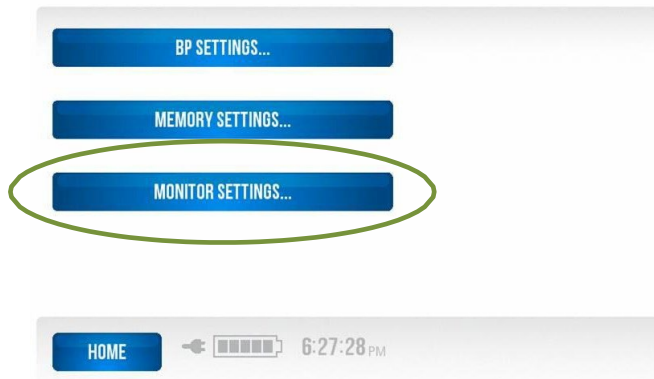

5. Press the **More** button.

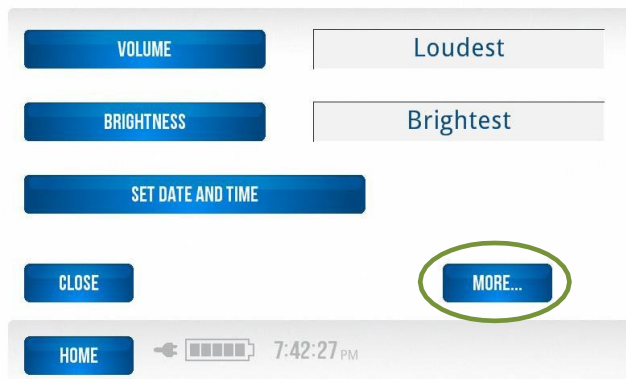

6. Press the **Table** button.



7. Select **Yes** and press the **OK** button to accept the change and return to the previous screen.

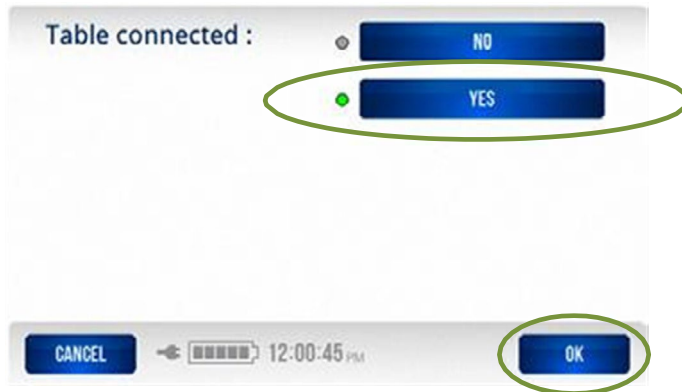

8. Press the **Home** button to return to the *Main Testing* screen.



When the Midmark Digital Vital Signs Device is configured to the Integrated Scale, the **Table Scale** icon will be present on the *Main Testing* screen, to the right of the CLEAR button.

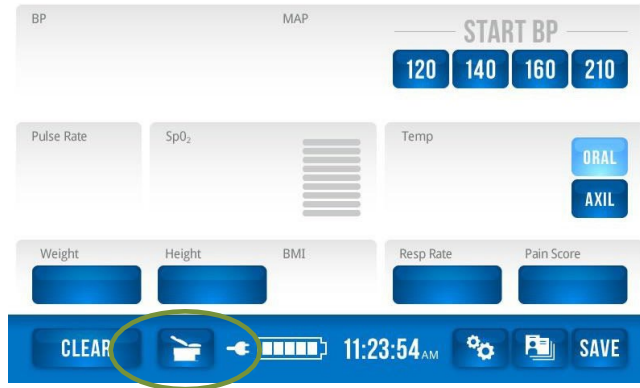

See [Section VIII – D. Scale Operation](#) for instructions on obtaining a weight measurement via the Integrated Scale.

XIV. Customer Support and Warranty Information

For help diagnosing problems by phone with this product, contact [Midmark Technical Service](#).

Self-help knowledge base and live chat can be accessed at kb.midmark.com.

Warranty

Midmark warrants Midmark Digital Vital Signs Device to be free from manufacturing and material defects for two (2) years from the original date of purchase. Warranty periods for accessories shipped at the time of original purchase are: one (1) year for blood pressure cuffs and SpO₂ sensor; 90 days for other accessories. Any misuse or abuse of a Midmark product or accessory voids all applicable warranties.

Please refer to midmark.com for the full and current Warranty Terms and Conditions.

Return Materials Authorization

To return any product for repair, a Return Materials Authorization (RMA) number must be obtained from [Midmark Technical Service](#). This RMA number should be referenced on the package(s) containing the items to be returned and in any correspondence regarding the return.

Shipping

Before shipping any unit to Midmark, be certain that an RMA number has been issued and that all guidelines regarding this authorization are followed. We highly recommend that you follow all guidelines for the shipment of medical products set forth by the shipping company you choose to use. If a question should arise regarding the appropriate method of shipment, please feel free to ask when calling for your RMA number. It is ultimately the responsibility of the customer when shipping a product to ensure that all packages and their contents get to Midmark safely. Midmark will not assume responsibility for damage due to improper packaging, shipment or product use. Such actions will void all applicable warranties.

XV. Disposal

The disposal of Midmark Diagnostic Devices and their accessories should be carried out according to local medical waste disposal policies and procedures. Do not discard these items in unsorted municipal waste. Contact your local waste disposal agency for guidance on proper recycling or disposal.

Certain items contain electronic circuit boards or lithium ion batteries that should not be incinerated, crushed, disassembled or exposed to extreme heat. Do not put the lithium ion battery in a refuse container. Lithium batteries and electronic components should be recycled appropriately.

XVI. Accessories and Supplies

The following table shows the accessories approved by Midmark for use with the Midmark Digital Vital Signs Device.



WARNING

Use only approved accessories with the Midmark Digital Vital Signs Device. Substitution of a component different from those suggested could result in measurement error.

Item	Part Number
Midmark Digital Vital Signs Device Thermal Printer	1-100-1605
Thermal Paper Roll, 50mm wide (Box of 10 rolls)	3-009-0054
AC Power Supply	3-009-0010
Fairbanks® TeleWeigh™ Digital Scale	1-100-1603
USB Cable 10'	3-009-0016
Adult Reusable SpO ₂ Sensor (Nellcor Compatible)	3-009-0020
Small Reusable SpO ₂ Sensor (Nellcor Compatible)	3-009-0021
SpO ₂ Extender Cable 4' (Nellcor Compatible)	3-009-0026
Power Supply Adapter Kit, Friwo	3-009-0012
Blood Pressure Hose 6.5'	3-009-0022
Blood Pressure Hose 10'	3-009-0100
Alaris® Turbo Temp® Oral/Axillary Temperature Probe	3-009-0024
Alaris Turbo Temp Probe Covers, Carton of 10 boxes (20 covers per box)	3-009-0058
Reusable Blood Pressure Cuff, Infant, 1 each (8-14 cm)	3-009-0068
Reusable Blood Pressure Cuff, Child, 1 each (13-20 cm)	3-009-0070
Reusable Blood Pressure Cuff, Small Adult, 1 each (18-26 cm)	3-009-0062
Reusable Blood Pressure Cuff, Adult, Midmark, 1 each (26-35 cm)	3-009-0064
Reusable Blood Pressure Cuff, Large Adult, Midmark, 1 each (32-42 cm)	3-009-0066
Reusable Blood Pressure Cuff, Adult Long, 1 each (26-38 cm)	3-009-0072
Reusable Blood Pressure Cuff, Large Adult Long, 1 each (35-44 cm)	3-009-0074
Reusable Blood Pressure Cuff, Thigh, 1 each (42-50 cm)	3-009-0076
Midmark Digital Vital Signs Device Lithium Ion Battery	3-009-0014
Midmark Digital Vital Signs Device Mobile Cart	3-004-2000
Midmark Digital Vital Signs Device Mobile Cart Printer Bracket	3-004-2004
Midmark Digital Vital Signs Device Wall Mount	3-009-0003
Midmark Digital Vital Signs Device Countertop Mount	3-009-0001
Midmark Digital Vital Signs Device Equipment Pole Mount	3-004-2008
Midmark Digital Vital Signs Device Mobile Cart Scale Mount (for Fairbanks® TeleWeigh™ Scale)	3-004-2010
Operation Manuals CD	3-100-1000
Midmark Digital Vital Signs Device Quick Reference Guide	3-100-1057
Midmark Digital Vital Signs Device Table Mount, IQhub®	9A551001
Midmark Digital Vital Signs Device Table Mount, Non-IQhub®	9A551002

XVII. Electromagnetic Compatibility (EMC) Information

Medical electrical equipment requires special precautions regarding electromagnetic compatibility (EMC). Portable and mobile radio frequency (RF) communications equipment can affect devices like the Midmark Digital Vital Signs Device. As such, the Midmark Digital Vital Signs Device should not be used adjacent to other equipment. If the Midmark Digital Vital Signs Device is used adjacent to such equipment, observe the Midmark Digital Vital Signs Device to make sure it is operating properly after installation.

The use of accessories other than those recommended by Midmark may result in increased EMC emissions or decreased EMC immunity of Midmark Digital Vital Signs Device.

Note

This device meets the requirements of IEC 60601-1. Please refer to this standard regarding safety requirements for this device.

Guidance and manufacturer's declaration: electromagnetic emissions		
The Midmark Digital Vital Signs Device is intended for use in the electromagnetic environment specified below. The user of the Midmark Digital Vital Signs Device should assure that it is used in such an environment.		
Emissions test	Compliance	Electromagnetic environment/guidance
RF emissions CISPR 11	Group 1	The Midmark Digital Vital Signs Device uses RF energy only for its internal function. Therefore, its RF emissions are very low and are not likely to cause any interference in nearby electronic equipment. The Midmark Digital Vital Signs Device is suitable for use in all establishments, including domestic establishments and those directly connected to the public low-voltage power supply network that supplies buildings.
RF emissions CISPR 11	Class B	
Harmonic emissions IEC 61000-3-2	Class A	
Voltage fluctuations/flicker emissions IEC 61000-3-3	Complies	

Guidance and manufacturer's declaration: electromagnetic immunity

The Midmark Digital Vital Signs Device is intended for use in the electromagnetic environment specified below. The user of the Midmark Digital Vital Signs Device should assure that it is used in such an environment.

Immunity test	IEC 60601 test level	Compliance level	Electromagnetic environment / guidance
Electrostatic discharge (ESD) IEC 61000-4-2	±6 kV contact ±8 kV air	±6 kV contact ±8 kV air	Floors should be wood, concrete, or ceramic tile. If floors are covered with synthetic material, the relative humidity should be at least 30%.
Electrical fast transient/burst IEC 61000-4-4	±2 kV for power supply lines ±1 kV for input/output lines	±2 kV for power supply lines ±1 kV for input/output lines	Mains power quality should be that of a typical commercial or hospital environment.
Surge IEC 61000-4-5	±1 kV differential Mode ±2 kV common mode	±1 kV differential Mode ±2 kV common mode	Mains power quality should be that of a typical commercial or hospital environment.
Voltage dips, short interruptions and voltage variations on power supply input lines IEC 61000-4-11	<5% UT (>95% dip in UT) for 0.5 cycle 40% UT (60% dip in UT) for 5 cycles 70% UT (30% dip in UT) for 25 cycles <5% UT (>95% dip in UT) for 5 s	<5% UT (>95% dip in UT) for 0.5 cycle 40% UT (60% dip in UT) for 5 cycles 70% UT (30% dip in UT) for 25 cycles <5% UT (>95% dip in UT) for 5 s	Mains power quality should be that of a typical commercial or hospital environment. If the user of the Midmark Digital Vital Signs Device requires continued operation during power mains interruptions, it is recommended that the Midmark Digital Vital Signs Device be powered from an uninterruptible power supply or a fully charged battery.
Power frequency (50/60 Hz) magnetic field IEC 61000-4-8	3 A/m	3 A/m	Power frequency magnetic fields should be at levels characteristic of a typical location in a typical commercial or hospital environment.

Guidance and manufacturer's declaration: electromagnetic immunity

The Midmark Digital Vital Signs Device is intended for use in the electromagnetic environment specified below. The user of the Midmark Digital Vital Signs Device should assure that it is used in such an environment.

Immunity test	IEC 60601 test level	Compliance level	Electromagnetic environment / guidance
<p>Conducted RF IEC 61000-4-6</p> <p>Radiated RF IEC 61000-4-3</p>	<p>3 Vrms 150 kHz to 80 Hz</p> <p>3 V/m 80 MHz to 2.5 GHz</p>	<p>3 Vrms</p> <p>3 V/m</p>	<p>Portable and mobile RF communications equipment should be used no closer to any part of the Midmark Digital Vital Signs Device, including cables, than the recommended separation distance calculated from the equation applicable to the frequency of the transmitter.</p> <p>Recommended separation distance is</p> $d = 1.2 \sqrt{P}$ $d = 1.2 \sqrt{P} \text{ 80 MHz to 800 MHz}$ $d = 2.3 \sqrt{P} \text{ 800 MHz to 2.5 GHz}$ <p>where P is the maximum output power rating of the transmitter in watts (W) according to the transmitter manufacturer, and d is the recommended separation distance in meters (m).</p> <p>Field strengths from fixed RF transmitters, as determined by an electromagnetic site survey^a, should be less than the compliance level in each frequency range^b.</p> <p>Interference may occur in the vicinity of equipment marked with the following symbol:</p> 

^a Field strengths from fixed transmitters, such as base stations for radio (cellular/cordless) telephones and land mobile radios, amateur radio, AM and FM radio broadcasts, and TV broadcast cannot be predicted theoretically with accuracy. To assess the electromagnetic environment due to fixed RF transmitters, an electromagnetic site survey should be considered. If the measured field strength in the location in which the Midmark Digital Vital Signs Device is used exceeds the applicable RF compliance level above, the Midmark Digital Vital Signs Device should be observed to verify normal operation. If abnormal performance is observed, additional measures may be necessary, such as re-orienting or relocating the Midmark Digital Vital Signs Device.

^b Over the frequency range 150 kHz to 80 MHz, field strengths should be less than 3 V/m.

Recommended separation distances between portable and mobile RF communications equipment and the Midmark Digital Vital Signs Device®

The Midmark Digital Vital Signs Device is intended for use in an electromagnetic environment in which radiated RF disturbances are controlled. The user of the Midmark Digital Vital Signs Device can help prevent electromagnetic interference by maintaining a minimum distance between portable and mobile RF communications equipment (transmitters) and the Midmark Digital Vital Signs Device as recommended below, according to the maximum output power of the communications equipment.

Rated maximum output power of transmitter (W)	Separation distance according to frequency of transmitter (m)		
	150 kHz to 80 MHz	80 MHz to 800 MHz	800 MHz to 2.5 GHz
	$d = 1.2 \sqrt{P}$	$d = 1.2 \sqrt{P}$	$d = 2.3 \sqrt{P}$
0.01	0.12	0.12	0.23
0.1	0.38	0.38	0.73
1	1.2	1.2	2.3
10	3.8	3.8	7.3
100	12	12	23

For transmitters rated at a maximum output power not listed above, the recommended separation distance d in meters (m) can be estimated using the equation applicable to the frequency of the transmitter, where P is the maximum output power rating of the transmitter in watts (W) according to the transmitter manufacturer.

Note 1

At 80 MHz and 800 MHz, the separation distance for the higher frequency range applies.

Note 2

These guidelines may not apply in all situations. Electromagnetic propagation is affected by absorption and reflection from structures, objects, and people.

XVIII. Contact Information

Technical Support is available Monday through Friday (except holidays), 6:00 am to 4:00 pm Pacific Standard Time.

Midmark Corporation

60 Vista Drive

Versailles, OH 45380 USA

Email: techsupport@midmark.com

T: 844.856.1230, option 2

Fax: 310.516.6517

midmark.com

kb.midmark.com (Knowledge Base)

Midmark Corporation

60 Vista Drive

Versailles, OH 45380 USA

T: 844.856.1230, option 2

Fax: 310.516.6517

